

## EVR "Extended Voltage Range" Technical Data

### Option for Sunny Centrals, the Sunny Family's Central Inverters

- EVR increases the max. permissible DC voltage, which may be present at the device's connection when idle, to 1000 V DC. This opens up new possibilities for the layout of the PV generator. Due to the higher input voltage, it is possible, if necessary, to increase the number of modules connected in series. For the system layout, the module data must be checked, and the maximum permissible system voltage and minimum temperature are to be taken into account. A higher number of modules connected in series reduces the effort and thus the costs of installing the PV generator.
- The EVR unit comprises the following components: a power resistor, one or two semiconductor switch(es), a control assembly, and a modified power module. The components are integrated into the Sunny Central. Depending on the device type, the power resistor is installed either in the device, or (externally) on the roof of the inverter cabinet.
- EVR can be implemented as an option for all Sunny Centrals, but is not yet available for all power classes. Details as to availability and delivery time are available upon request. It is not possible to implement EVR for LV (low voltage) devices.

The additional technical data for EVR devices is listed below. Data which does not differ to that of a standard device is not listed here. For this data, please refer to the data sheet of the respective device type.

Sunny Central with EVR	Symbol	
<b>Additional delivery contents</b>		
<ul style="list-style-type: none"> <li>• Semiconductor switch with control assembly integrated in the Sunny Central</li> <li>• Power resistor</li> <li>• Modified power module</li> </ul>		
<b>Input data</b>		
Max. PV power (recommended)	$P_{PV}$	depends on the inverter
DC voltage range, MPPT	$U_{DC}$	450 - 820 V
Max. permissible DC voltage	$U_{DC, max}$	1000 V
Max. permissible DC current	$I_{DC, max}$	depends on the inverter
Number of DC inputs / terminal		depends on the inverter
<b>Dimensions and weight</b>		
With the exception of the SC100, the power resistor is installed on the roof of the inverter cabinet. It is delivered separately, and installation occurs on site. Please observe the necessary minimum clearances to the device and to the resistor (see installation requirements).		
No flammable materials may be situated in the vicinity of the resistor! Cooling occurs by means of natural convection. Allowance must be made for ventilation of the resistor at the front, rear, and top.		
Additional height (without minimum clearance and depending on the device type) [mm]	H	210
Minimum clearance above the resistor [mm]		120
Additional weight (depending on the device type) [kg]	m	approx. 50

Sunny Central with External Power Resistor (Example SC500HE)

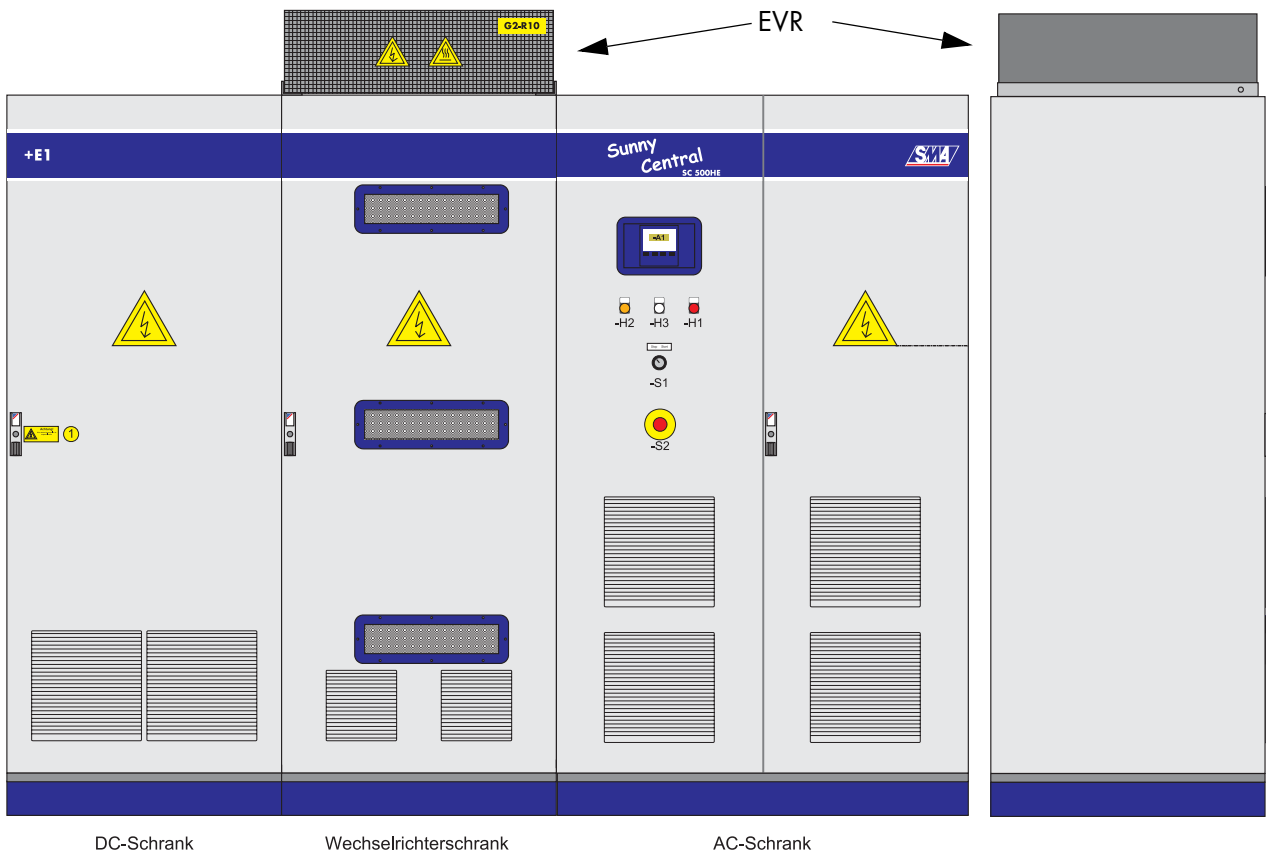

Front view

Side view

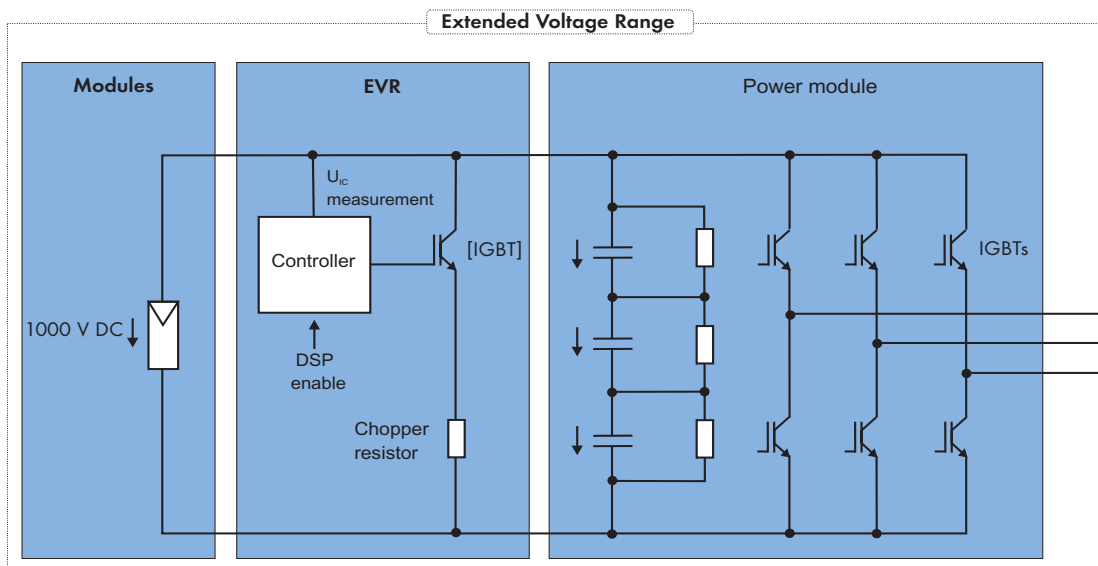

Block circuit diagram of EVR with power module