



Sunny Boy 700

String Inverter Sunny Boy 700



Explanation of Symbols used in this Document

This symbol indicates information that is essential for a trouble-free and safe operation of the product. Please read these sections carefully in order to avoid any damages of the equipment and for optimal personal protection.



This symbol indicates information that is required for the optimal operation of the product. Read these sections carefully in order to ensure an optimal operation of the product and all its features.



This symbol indicates an example.



Liability exclusion

The information contained in this documentation are the property of **SMA Technologie AG**. No part of this documentation may be published without written permission from **SMA Technologie AG**. A reproduction for internal purposes for the evaluation of the product or an appropriate application is permitted and does not require authorization.

All information are based on our "General Terms and Conditions of Delivery of **SMA Technologie AG**". The content of this documentation is reviewed continuously and adjusted, if necessary. **SMA Technologie AG** provides this documentation without exclusion of deviations and without warranty of completeness. You will find the current version on the Internet at www.SMA.de or can obtain it via the usual sales channels. Warranty or liability claims for all kinds are excluded in case of damages due to:

- Inappropriate use of the product
- Operation of the product in an improper environment
- Operation of the product without considering the relevant safety regulations
- Non-fulfillment of the warnings or safety instructions described in the documentation for the product
- Operation of the product under faulty conditions concerning security and protection
- Arbitrary changing of the product or the provided software
- Failure of the product due to interference of connected or contiguous devices out of legal limit values
- Disasters and force majeure

Software Licensing

The use of the provided software by **SMA Technologie AG** is subject to the following conditions: The software may be reproduced for internal purposes and installed on any number of computers. Provided source codes can be changed and adjusted on the company's own authority according to the internal purpose. Driver may be ported to other operating systems as well. No part of the source codes may be published without written permission of **SMA Technologie AG**. Sublicensing of the software is not acceptable.

Liability limitation: **SMA Technologie AG** disclaims liability for any direct or indirect consequential damages arising from the use of the software produced by **SMA Technologie AG**. The same applies for the provision and/or non-provision of support.

Provided software not produced by **SMA Technologie AG** is subject to the respective licensing and liability agreements of the manufacturer.

Trademarks

All brand and product names used herein are trademarks or registered trademarks of their respective holders, although they may not be specifically designated as such.

SMA Technologie AG

Hannoversche Strasse 1-5

34266 Niestetal

Germany

Tel. (+49) 5 61 95 22 – 0

Fax (+49) 5 61 95 22 – 100

www.SMA.de

E-Mail: info@SMA.de

© 2005 **SMA Technologie AG**. All rights reserved.

Table of Contents

1	Foreword	7
2	Safety information	9
3	Overview	11
3.1	Unit description	11
3.2	External dimensions	12
4	Installation requirements	13
4.1	Installation site requirements	13
4.2	PV generator requirements	15
4.3	Low voltage grid 230 V (AC)	15
5	Installation	19
5.1	Mounting the unit	19
5.2	Electrical installation	20
5.3	Setting the input voltage	27
5.4	Startup	30
6	Opening and closing the Sunny Boy	33
6.1	Opening the Sunny Boy	33
6.2	Closing the Sunny Boy	33
7	Technical data	35
7.1	Input voltage range 119 ... 250 V DC	35
7.1.1	PV generator connection data	35
7.1.2	Grid connection data	35
7.2	Input voltage range 96 ... 200 V DC	36
7.2.1	PV generator connection data	36
7.2.2	Grid connection data	36
7.3	Input voltage range 73 ... 150 V DC	37
7.3.1	PV generator connection data	37
7.3.2	Grid connection data	37
7.4	Device description	38
7.5	Operating parameters	39
8	Replacing the varistors	41
9	Rating for a line circuit breaker	45
10	Contact	49

1 Foreword

The installation of the Sunny Boy may only be done by qualified technicians. The installer must be approved by the utility company. Please read the installation guide carefully before you begin with the installation. The installation of utility interactive power sources must be compliant with all applicable regulations of the utility company and with all applicable regulations and standards.



The Sunny Boy 700 is equipped with the SMA grid guard. This is a type of independent disconnection device. It ensures that the Sunny Boy 700 complies with the VDEW (Verband der Elektrizitätswirtschaft – German Electricity Industry Association) regulations for the connection and parallel operation of electrical power units to the low-voltage grid of the electricity supply company and with DIN VDE 0126 (4.99) which is a part of these regulations.



This installation manual is intended solely for qualified electricians. Its aim is to help install and set up SMA Sunny Boy SB 700 inverters quickly and correctly.

For detailed information on troubleshooting and on how to use the Sunny Boy 700, including information about the different communication options, please see the operating instructions.

The „Sunny Design“ tool will help to dimension and check the size of your strings with respect to the inverter you intend to use. Further information about „Sunny Design“ is available at www.SMA.de.

If your Sunny Boy is equipped with a communication interface, you will find detailed instructions for installation in the description of the communication interfaces (Piggy-Backs), which has been delivered with the device.

If you require further information, please call the Sunny Boy hotline on the following number:

+49 (0)561 95 22-499

2 Safety information

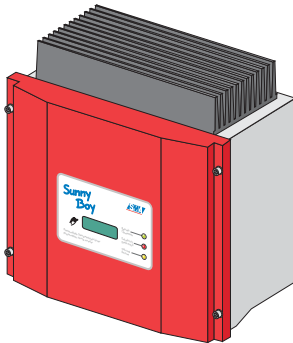

Check your plant configuration and the string sizing with „Sunny Design“ (available at www.SMA.de) or with the Sunny Boy Hotline before you start with the installation. Exceeding the specifications with the input voltage will destroy the Sunny Boy. Overvoltage on the DC side can even cause dangerous explosions of the Sunny Boys input capacitors and explosions of the electrolytes coming from the exploded capacitors.



Work on the Sunny Boy with the lid removed must be carried out by a qualified electrician. Hazardous and even lethal voltages can be encountered within the enclosure. Before working on the Sunny Boy with the lid removed, the AC and DC voltages **MUST** be disconnected from the Sunny Boy and it must be sure that all capacitors are discharged.



The Sunny Boy must be disconnected from the mains and precautions must be taken to prevent the grid being reconnected. In addition, the connections to the PV generator must be disconnected.

After isolating the AC and DC voltage you must wait approx. 30 minutes for the capacitors in the Sunny Boy to discharge. Only then is it safe to open the unit by removing the lid. You must also make sure that no voltage is present in the device.

The electronics inside your Sunny Boy 700 is vulnerable in terms of electrostatic discharge. Be sure to be connected to ground (e.g. the enclosure of the Sunny Boy) before handling anything within the enclosure of the Sunny Boy.



3 Overview

3.1 Unit description

The following diagram gives a schematic overview of the various components and connection points inside the Sunny Boy 700 with the lid removed:

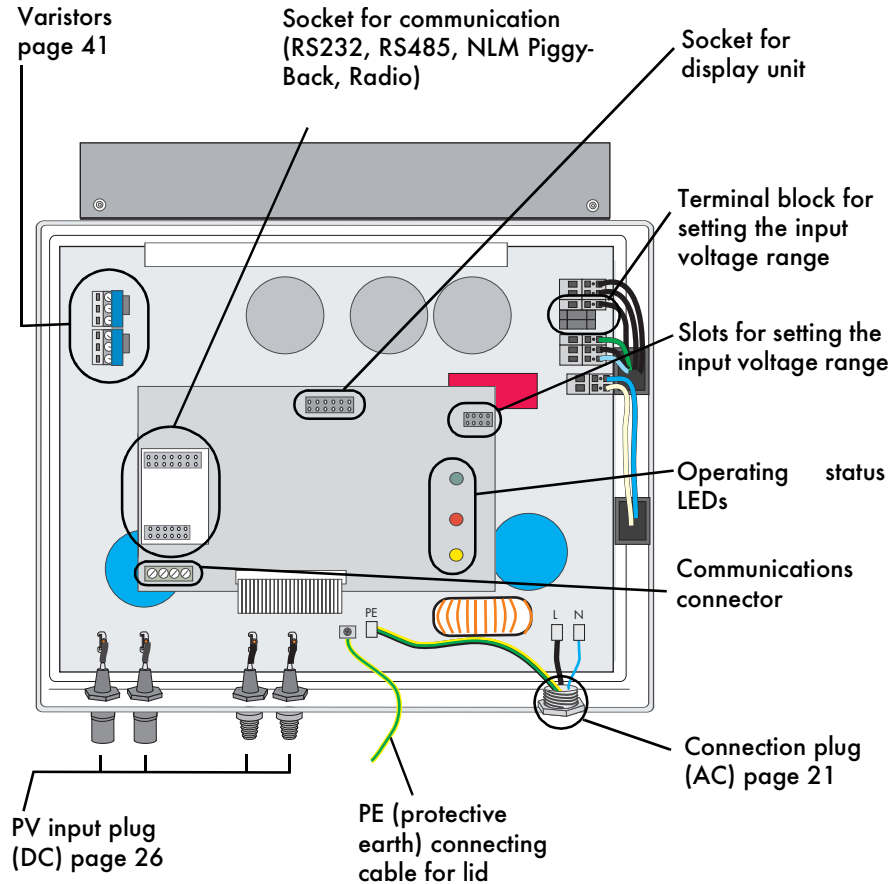

3.2 External dimensions

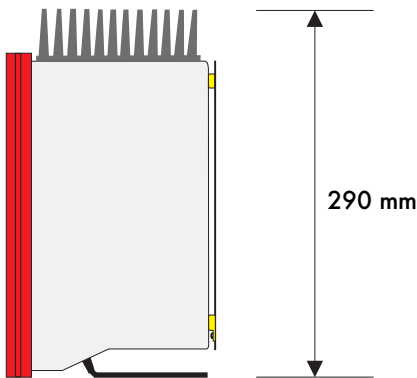
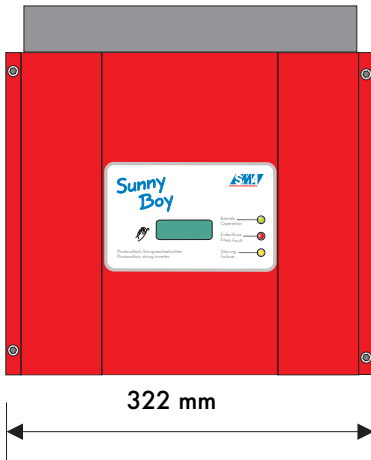
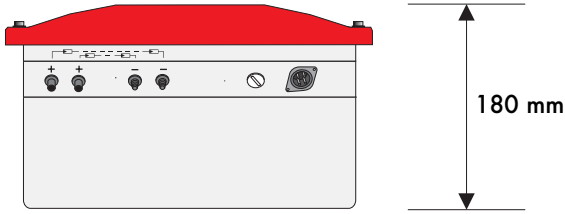

4 Installation requirements

Please check that all of the conditions listed below are met before installing and setting up the Sunny Boy.

4.1 Installation site requirements

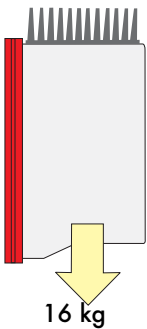

The Sunny Boy 700 weighs 16 kg. Please take this weight into account when choosing the installation site and method of installation.

The ambient temperature must be within $-25\text{ }^{\circ}\text{C}$ to $+60\text{ }^{\circ}\text{C}$.



The Sunny Boy 700 should be installed in a place where it is not exposed to direct sunlight. An increased ambient temperature can reduce the yield of the PV system.

The Sunny Boy is designed to be mounted on a vertical wall. For an optimum energy yield and the most convenient operation, vertical installation at eye-level is preferable. In case it is absolutely necessary to tilt the Sunny Boy to the back the maximum angle is 45 ° . If installing the unit outdoors, make sure that it is not slanting forwards.

It is not recommended to install the Sunny Boy lying on the back side with the lid facing upwards.

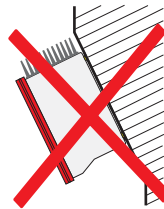
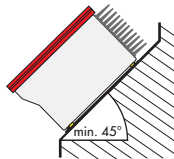
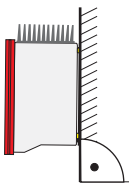

Mount the Sunny Boy in a vertical position or with a slight angle to the back.

Do not mount the Sunny Boy with an angle to the front or on the back.

When choosing the installation site, be sure to note the following:



Unintentionally pulling out the DC plug connector under load can damage the plug and result in bodily injury or death! Install the Sunny Boy in such a way that it is not possible (e.g. for children) to unplug the DC plug connector unintentionally.



Individual components in the Sunny Boy can reach a temperature of more than 60 °C.



Do not install the Sunny Boy on flammable construction materials, in areas where highly inflammable materials are stored or in potentially explosive environments!

When choosing the installation site, ensure there is enough space for heat to dissipate. Under normal conditions, the following guidelines should be applied for the space to be kept clear around the Sunny Boy 700:

	Minimum clearance
Sides	20 cm
Top	20 cm
Underneath	20 cm
In front	5 cm

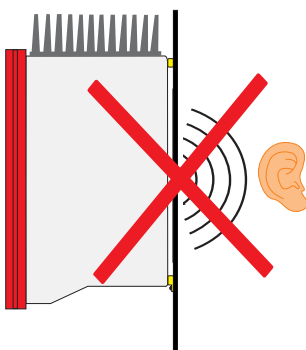
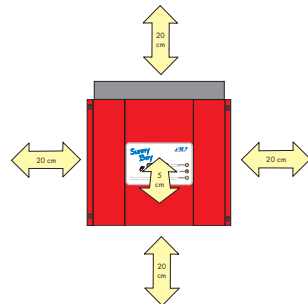

In domestic installations, the unit should not be mounted on plasterboard walls or similar as otherwise audible vibrations are likely to result.

We recommend securing the unit to a solid surface.

The Sunny Boy 700 will emit a slight noise during operation. This noise can be annoying when the Sunny Boy is installed within a living area.

4.2 PV generator requirements

The Sunny Boy 700 is designed to be connected to up to two strings (PV modules wired in series) having a homogenous structure (modules of the same type, identical orientation, tilt and number).

The „Sunny Design“ tool will help to dimension and check the size of your string with respect to the inverter you intend to use. Information about the „Sunny Design“ tool is available at www.SMA.de.

The unit has four DC plug connectors (two for each string) for connecting the PV generators. The connecting cables from the PV generators must also be fitted with this type of plug connector. A pre-assembled set for connecting the free cable ends from a string is available as an optional accessory. The SMA order codes for the various connectors are as follows:

- Multi-contact 3 mm: "SWR-MC"
- Multi-contact 4 mm: "MC-SET"
- Tyco: "TYCO-SET"

Limit values for DC input	
Max. voltage	250 V (DC)
Max. input current	10 A (DC)

4.3 Low voltage grid 230 V (AC)

The Sunny Boy must have a three-conductor connection to the mains (live (L), neutral (N), protective earth (PE)).

The grid connection terminals on the AC connection socket included in the accessories kit can take wires with a cross-section of up to 2.5 mm². The accessories kit also contains a PG13.5 AC connection socket for connecting cables with a diameter between 9 mm and 13.5 mm, while the PG16 connection socket is used for cables with a diameter up to a maximum of 17 mm. For detailed instructions, see sections "Connecting the AC output with PG13.5" (page 22) and "Connecting the AC plug with PG16" (page 24).

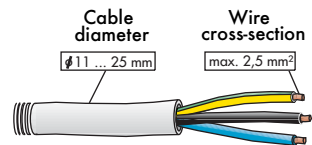



We recommend using a 16 A line circuit breaker to protect the power circuit. No loads should be connected to this power circuit.

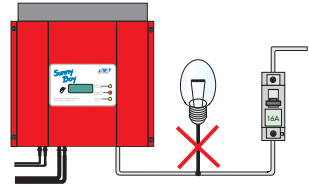

Rating for a line circuit breaker in a photovoltaic electrical power unit operated in parallel with the low-voltage grid

Various factors should be taken into account when selecting line circuit breakers. These include, for example:

- The type of cable used (conductor material and insulation)
- Ambient temperatures affect the cables (higher temperatures result in a reduced maximum current load)
- Method of routing the cable (reduces the ampacity of the conductor)
- Bundling cables together (reduces the ampacity of the conductor)
- Loop impedance [Z] (in the event of a body contact this limits the current that can flow and therefore determines the response behaviour of the circuit breaker)
- Adequate clearance between the circuit breakers in order to avoid excessive heating (automatic circuit breakers trip earlier when they are warmer)
- Selectivity
- Protection class of the connected load (VDE 0100, part 410), Protection against electric shock



Please have a look at chapter 9 "Rating for a line circuit breaker" (page 45).

The following standards¹ should be followed in all cases:

- DIN VDE 0298-4 (Cable routing and current-carrying capacity)
- DIN VDE 0100; part 430 (Protective measures; protection of cable and cords against overcurrent)
- DIN VDE 0100; part 410 (Protective measures; protection against electric shock)

1. The standards mentioned above are to be only used as a guideline for your installation. They apply for installations in Germany. Please note that other standards will apply for different countries throughout the world.

The system impedance at the installation site of the Sunny Boy 700 must be less than 1 Ohms for the islanding detection and the fuses to work properly. In addition, we recommend dimensioning the cable cross-section so that line losses do not exceed 1% at the nominal power. Line losses depending on the cable length and cross-section are shown in the graph below. It shows a multi-conduit cable with all conduits made of copper.

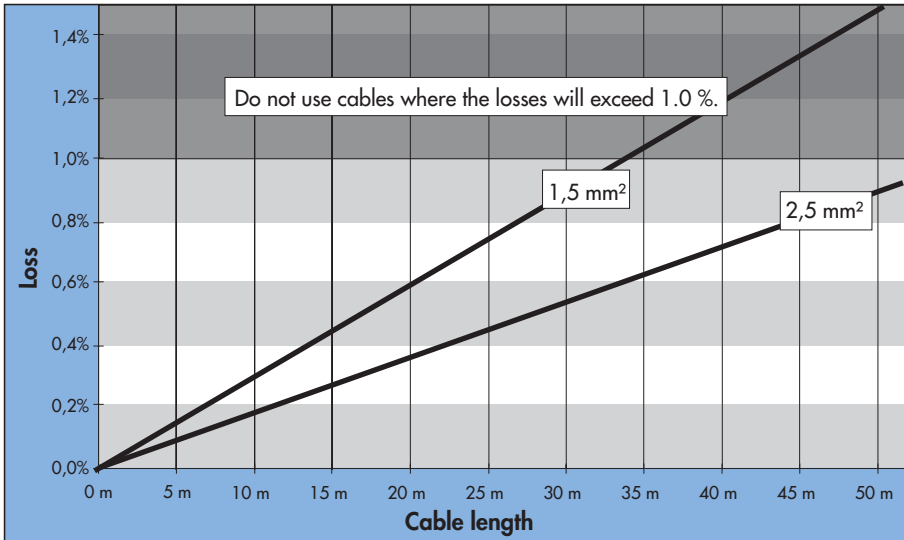

The maximum cable lengths for the different cable cross-sections are as follows:

Cable cross-section	1.5 mm ²	2.5 mm ²
Max. length	33 m	55 m

The Sunny Boy 700 is designed for operation on 230 V grids and works at grid voltages of 198 V to 260 V at 49.8 Hz to 50.2 Hz.

	Limit values for AC output
Voltage range	198 V ... 260 V
Frequency range	49.8 Hz ... 50.2 Hz
Voltage range (without MSD)	180 V ... 260 V
Frequency range (without MSD)	45.5 Hz ... 54.5 Hz

The Sunny Boy 700 is equipped with an automatic 50 Hz / 60 Hz utility frequency detection. It can therefore be connected to a 50 Hz or 60 Hz utility without any further configuration changes. Pay attention to the local utility regulations in any case.

5 Installation

5.1 Mounting the unit

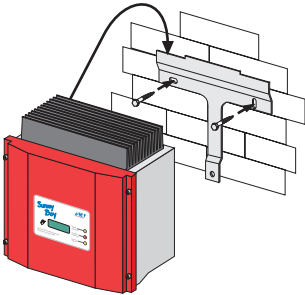

To make the job easier, we recommend you use the supplied wall bracket to mount the Sunny Boy 700. For vertical installation on solid concrete or block walls, for example, you can fit the bracket using 8 mm x 50 mm hexagon bolts to DIN 571 standard, stainless steel type, and with wall plugs type SX8.

When selecting the mounting materials, be sure to take into account the weight of the Sunny Boy 700 (16 kg).

1. Fit the wall bracket (1). To mark the positions to drill the holes, you can use the wall bracket as a drilling template.
2. Now hook the Sunny Boy 700 onto the wall bracket (2) at its upper mounting plate so that it cannot be moved sideways.
3. Fix the Sunny Boy 700 onto its bracket by screwing the supplied M6x10 bolt into the central threaded hole at the bottom of the bracket (3).
4. Make sure the Sunny Boy 700 is positioned securely on the bracket.

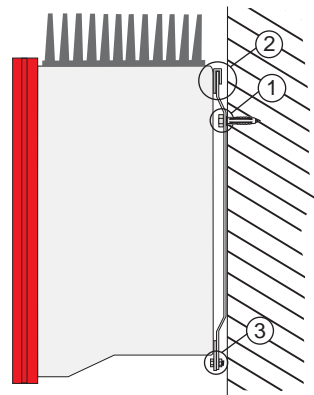

5.2 Electrical installation



Check the correct polarity before you connect the PV strings!

The complete wiring for a Sunny Boy 700 is shown schematically in the following diagram:

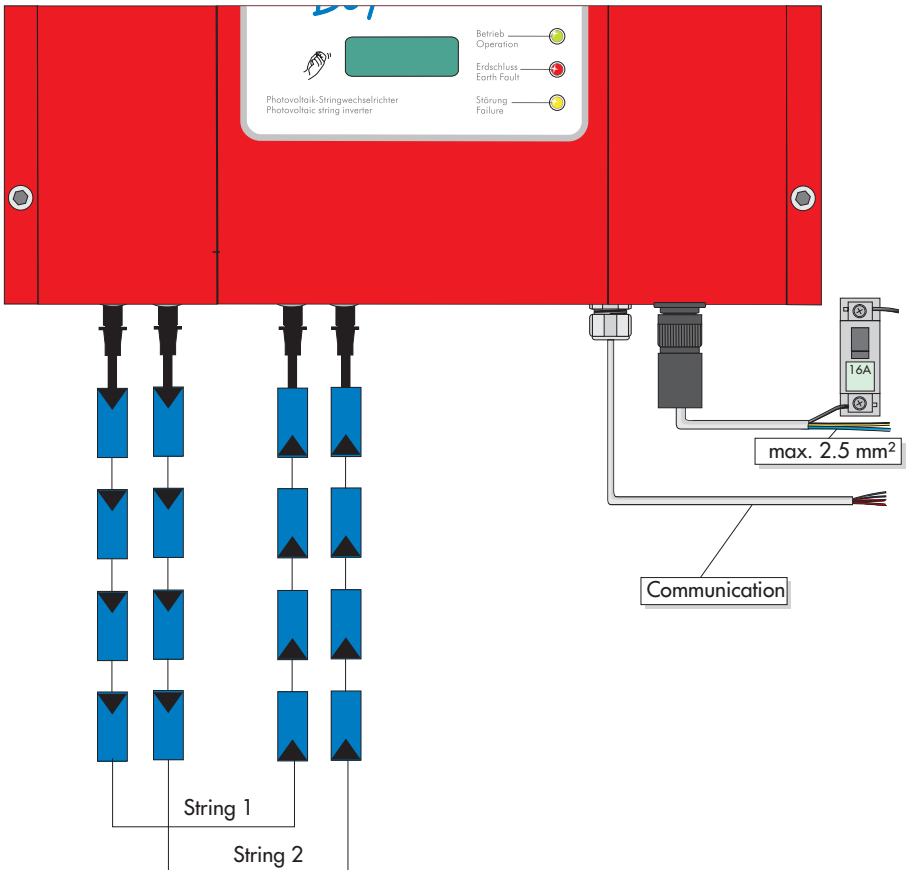

Connecting the AC output

Before you connect the mains cable to the AC connection socket, make sure that no voltage is present at the cable.



A round plug connector system is used, which allows various cable diameters to be used in the cable outlet. For this reason, the accessories kit includes a PG13.5 pressure screw and a PG16 pressure screw. Check which screw fitting is the right one for your AC cable.

To connect up the AC output, follow these steps:

1. Check the grid voltage. If this is higher than 260 V, the Sunny Boy 700 will not be fully operational. In this case, contact the local grid operator for assistance.



Max. 260 V!

The maximum grid voltage for feeding electricity into the grid is 260 V!

2. Isolate the grid connection (switch the line circuit breaker to its "off" position), make sure it cannot be switched back on, and test to make sure no voltage is present.

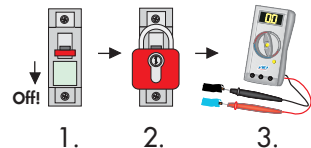

You must make sure that no voltage is present at the AC output before opening the Sunny Boy.

3. Now take the AC connection socket parts included in delivery of your Sunny Boy 700 and connect up the cable, with shielding and insulation stripped, as described on the following pages:

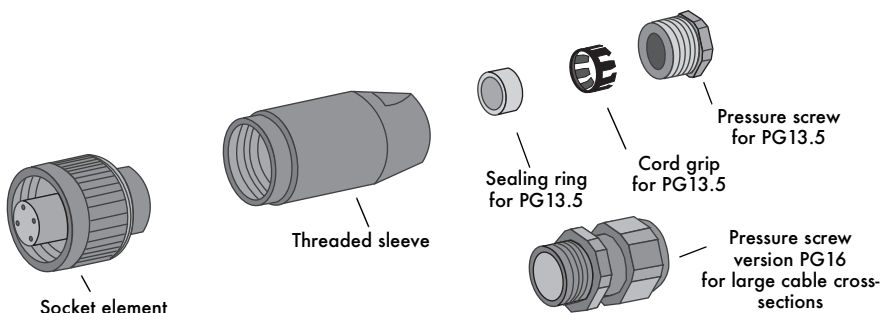

Connecting the AC output with PG13.5

To connect a cable with a maximum diameter of 13.5 mm, proceed as follows.

1. Press the sealing ring into the cord grip.

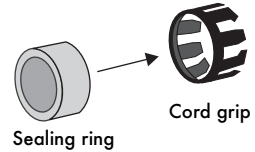

2. Now slide the pressure screw over the cable first of all, followed by the cord grip with the sealing ring in it. Now slide the threaded sleeve over the cable.

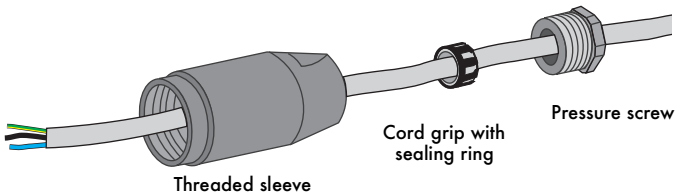

3. Now connect the individual conductors to the socket element in sequence.

- Protective earth PE (green/yellow) to the screw terminal with the earth sign. It is required that the PE wire is slightly longer than the L and N wires.
- Neutral conductor N (blue) to screw terminal 1.
- Live L (brown or black) to screw terminal 2.
- Terminal 3 remains unused.

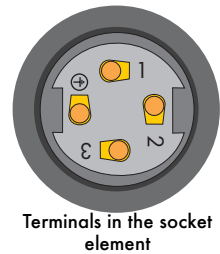

4. Make sure the wires are securely connected.

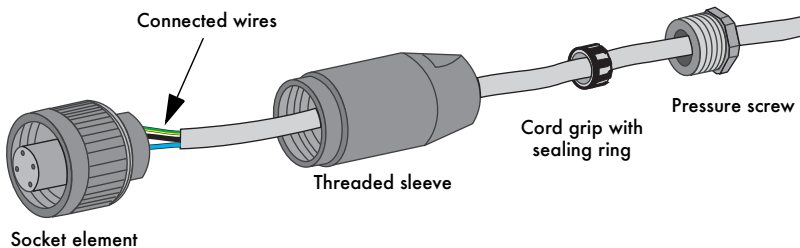

5. Now screw the threaded sleeve onto the socket element and tighten it.

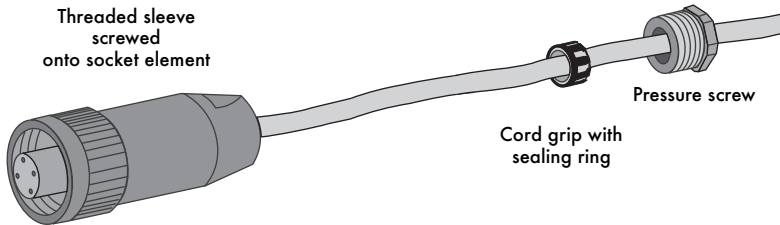

6. Now screw the pressure screw into the threaded sleeve and tighten it. The cord grip with the sealing ring is pressed into the threaded sleeve and can no longer be seen.

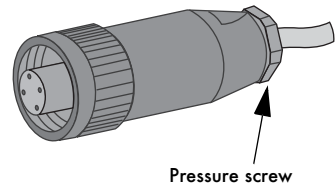

The AC connecting socket is now fully assembled.

If you are not going to connect up the Sunny Boy immediately, close off the socket element using the cap supplied in the accessories kit.

If the Sunny Boy is already installed, you can now connect up the fully assembled AC connection socket to the flange plug on the Sunny Boy. To do this, remove the protective cap from the flange plug on the Sunny Boy. Firmly tighten the threaded ring on the AC connecting socket to the flange plug to seal the connection and secure it.

Do not switch the line circuit breaker on yet! The Sunny Boy 700 may only be connected to the AC grid once the PV strings are connected and the device is securely closed.



Connecting the AC plug with PG16

To connect a cable with a diameter between 13.5 mm and 16 mm, proceed as follows.

1. First of all, slide the pressure screw with the PG16 screw fitting onto the cable. Now slide the threaded sleeve over the cable.

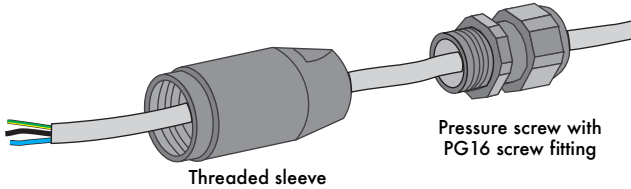

2. Now connect the individual conductors to the socket element in sequence.

- Protective earth PE (green/yellow) to the screw terminal with the earth sign. It is required that the PE wire is slightly longer than the L and N wires.
- Neutral conductor N (blue) to screw terminal 1.
- Live L (brown or black) to screw terminal 2.
- Terminal 3 remains unused.

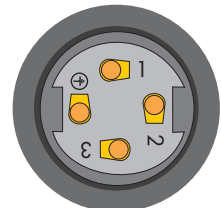

Terminals in the socket element

3. Make sure the wires are securely connected.

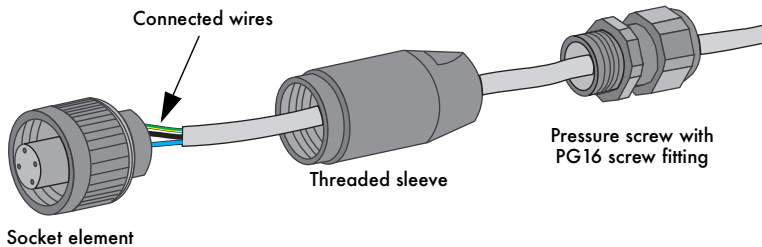

4. Now screw the threaded sleeve onto the socket element and tighten it.

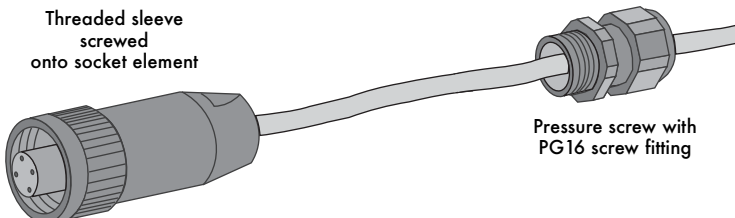

5. Now screw the pressure screw into into the threaded sleeve and tighten it.
6. Firmly tighten the screw fitting against the seal and in order to fasten the cable.

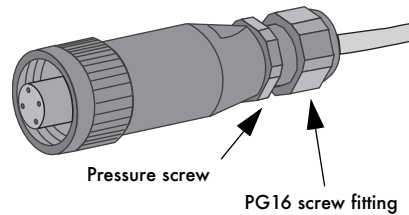

The AC connecting socket is now fully assembled.

If you are not going to connect up the Sunny Boy immediately, close off the socket element using the cap supplied in the accessory kit.

If the Sunny Boy is already installed, you can now connect up the fully assembled AC connection socket to the flange plug on the Sunny Boy. To do this, remove the protective cap from the flange plug on the Sunny Boy. Firmly tighten the threaded ring on the AC connecting socket to the flange plug to seal the connection and secure it.

Do not switch the line circuit breaker on yet! The Sunny Boy 700 may only be connected to the AC grid once the PV strings are connected and the device is securely closed.



PV string (DC) connection

To connect up the input, follow these steps:

1. Check that the PV generator connectors have the right polarity and do not exceed the maximum string voltage of 250 V (DC). See also section 4.2 "PV generator requirements" (page 15).

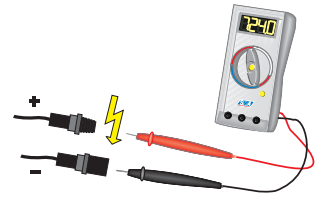

Caution! Dangerous high voltages may be present. Danger of death!

2. Taking one DC plug connector at a time, measure the direct current voltage between one DC plug connector of a string and earth potential.
3. If the measured voltages are constant and if their total is roughly the same as the open circuit voltage of the string then there is a earth fault in this string. Its approximate location can be deduced from the relationships between the voltages.

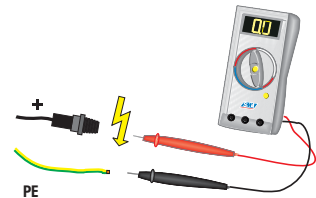

Do not connect strings to the Sunny Boy 700 that contain a earth fault until you have fixed the earth fault in the PV generator.

4. Repeat points 2 and 3 for each string.
5. Connect up the faultless PV generator strings to the inverter.
6. Close off the unneeded DC input sockets using the protective caps in the accessories kit.

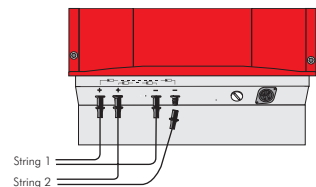

5.3 Setting the input voltage

The Sunny Boy 700 was developed for a nominal output power of 700 W. This corresponds to a PV input voltage range of 119 ... 250 V DC at the nominal output voltage.

For solar generators having an input voltage range of 96 ... 200 V DC or 73 ... 150 V DC it is possible to adjust the Sunny Boy 700's input voltage range accordingly. In other words, it is also possible to connect smaller PV generators to the Sunny Boy 700.

Input voltage range	Nominal output power
119 ... 250 V DC	700 W
96 ... 200 V DC	600 W
73 ... 150 V DC	460 W

For small PV systems please note:

The Sunny Boy 700 must be adjusted for the number of PV modules so that it works in the optimum range.



The Sunny Boy 700 is factory set for the highest input voltage. To be able to use it for smaller PV systems, you need to make some minor modifications to the unit. Inside the Sunny Boy 700 at the top right there are a number of terminal blocks. The top double terminal is not relevant for adjusting the input voltage range. Below the double terminal there is a single terminal. This terminal is used to adjust the input voltage. Below this terminal there are two free slots. You can see the input voltage ranges associated with the slots from the drawing below.

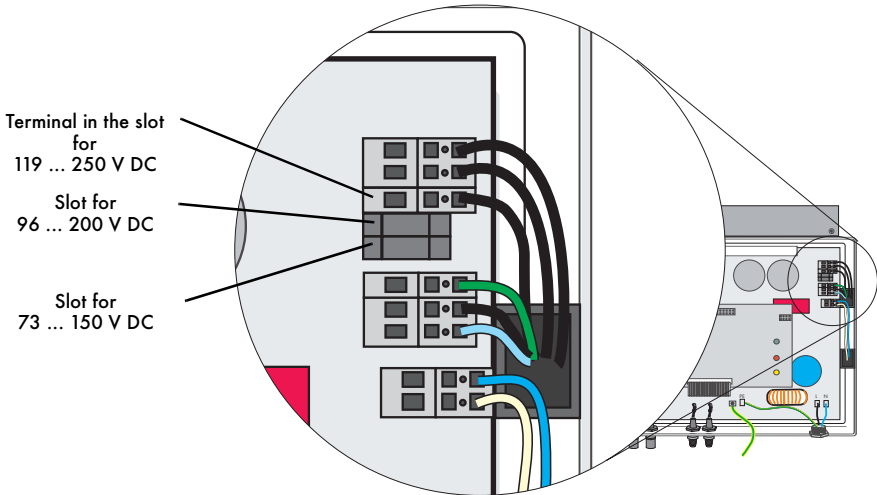

The slots for the jumpers are mounted on the Sunny Boy 700's controller board. When supplied from the factory, no jumper is fitted. A jumper only needs to be used if you want to operate the Sunny Boy 700 with a lower input voltage, i.e. at 96 ... 200 V DC or at 73 ... 150 V DC.

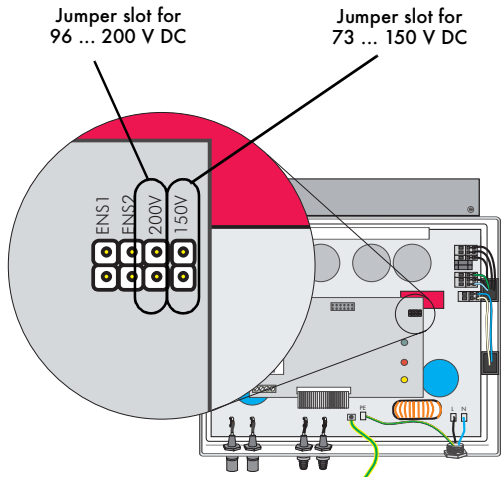

To adjust the input voltage, follow these steps:

1. Open the Sunny Boy 700 as described in section 6.1.
2. Pull the terminal upwards out of the terminal block and plug it into the appropriate slot.
3. Plug the jumper provided in the accessories kit into the corresponding slot on the controller board. If you want to use the Sunny Boy 700 with the maximum input voltage range, then do not use the jumper.
4. Once the jumper is in place and the terminal plugged into the correct slot, close the Sunny Boy 700 as described in section 6.2.

There is a schematic view of the connectors in the table below.

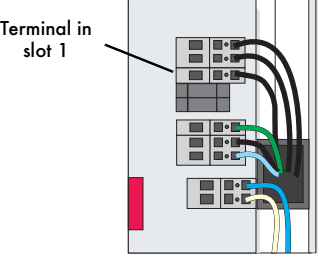
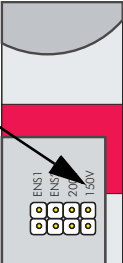
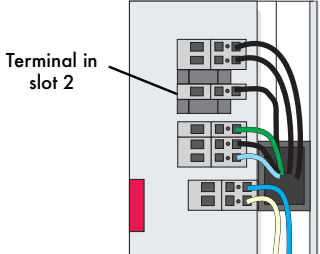
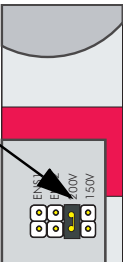
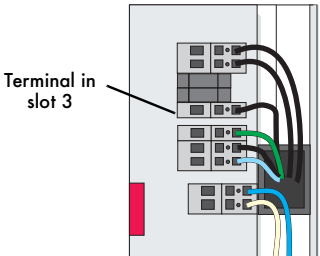
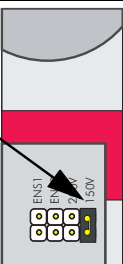
Voltage range	Terminal block	Jumper
119 ... 250 V DC (factory setting)	 <p>Terminal in slot 1</p>	 <p>No jumper used</p>
96 ... 200 V DC	 <p>Terminal in slot 2</p>	 <p>Jumper fitted to "200 V" position</p>
73 ... 150 V DC	 <p>Terminal in slot 3</p>	 <p>Jumper fitted to "150 V" position</p>

5.4 Startup

You can start up the Sunny Boy 700 when

- the lid is securely screwed on the enclosure,
- the AC (mains) cable is connected correctly,
- the DC cables (PV strings) are fully connected and the unused DC plug connectors on the bottom of the enclosure are closed using the protective caps.

How to start up the inverter

1. First of all, switch the line circuit breaker to the "on" position.
2. Check whether the LEDs indicate trouble-free operation of the Sunny Boy 700 based on the table on the next page. In that case, startup has been successfully completed.

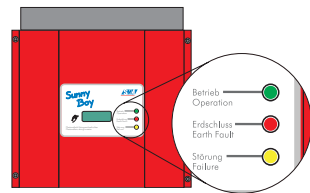
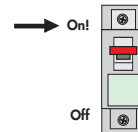

If the bottom yellow LED flashes four times at intervals of one second, the grid voltage and the PV generator must be disconnected from the Sunny Boy 700 immediately! There is a risk of damage to the inverter resulting from excessive DC input voltage.

Check the string voltages again to make sure they are within the limits stated in section 4.2 "PV generator requirements" (page 15). If the string voltages are too high, the PV generator's planner / installer should be called upon for assistance.

If despite checking the string voltages the LED signal occurs again when the PV generator is connected to the Sunny Boy 700, disconnect the PV generator from the Sunny Boy again and contact **SMA Technologie AG** (see section 10 "Contact" (page 49)).

Green	Red	Yellow	Status
on	off	off	OK (feeding grid)
	on	off	failure
		on	OK (initialization)
blinking quickly (3 x per second)	off	off	OK (stop)
	on	off	failure
on / blinking (1 x per second)	off	off	OK (waiting, grid monitoring)
	on	off	failure
on / blinking (shortly off 1 x per second)	off	off	OK (derating)
	on	off	failure
off	off	off	OK (night standby)
		on / blinking	failure
	on	off	failure
		on / blinking	failure

For a detailed description of the fault messages and their causes, see the operating instructions.

6 Opening and closing the Sunny Boy

If you need to open the device for whatever reason, please pay attention to section 2 "Safety information" (page 9).



6.1 Opening the Sunny Boy

Caution: Follow the sequence below under all circumstances.



1. Switch the line circuit breaker to the "off" position.
2. Disconnect the PV generator from the Sunny Boy 700.
- 3. Wait 30 minutes!**
4. Remove the four screws from the lid and pull the lid off the enclosure. Unlock the green-yellow PE connection and remove it from the lid and take the lid off.

6.2 Closing the Sunny Boy

Caution: Follow the sequence below under all circumstances.



1. Reconnect the earth wire (PE) to the lid. Now secure the lid to the Sunny Boy 700 by tightening the four screws evenly.
2. Connect the PV generator.
3. Switch the line circuit breaker to the "on" position.
4. Now check whether the LED display on the Sunny Boy 700 indicates that the device is functioning correctly.

7 Technical data

7.1 Input voltage range 119 ... 250 V DC

7.1.1 PV generator connection data

Max. input open circuit voltage	U_{PV0}	250 V (based on -10 °C cell temperature)
Input voltage, MPP range	U_{PV}	119 V ... 250 V
Max. input current	I_{PVmax}	7 A
Max. input power	P_{DC}	780 W
Recommended generator power		900 Wp
All-pole isolator on the DC input side		DC plug connector
Overvoltage protection		Thermally monitored varistors
Voltage ripple	U_{PP}	< 10 % of the input voltage
Insulation protection		Ground fault monitoring (Riso > 1 MΩ)
Operating consumption		< 4 W (standby)
Reverse polarity protection		Short circuit diode

7.1.2 Grid connection data

Nominal output power	P_{ACnom}	700 W
Peak output power	P_{ACmax}	700 W
Nominal output current	I_{ACnom}	3 A
Harmonic distortion of output current (at $K_{Ugrid} < 2\%$, $P_{AC} > 0.5 P_{ACnom}$)	K_{IAC}	< 3 %
Short-circuit strength		Grid-side via current regulation
Operating range, grid voltage	U_{AC}	198 ... 260 V AC
Operating range, grid frequency	f_{AC}	49.8 ... 50.2 Hz
All-pole isolation on grid side		Independent disconnection device (MSD), redundant design
Phase shift angle (based on the current's fundamental frequency)	$\cos \phi$	1
Overvoltage category		III
Test voltage (50 Hz)		1.3 kV (1 s routine testing / 5 s type testing)
Test surge voltage		4 kV (serial interface: 6 kV)
Own consumption in night mode		0.1 W

7.2 Input voltage range 96 ... 200 V DC

7.2.1 PV generator connection data

Max. input open circuit voltage	U_{PV0}	250 V (based on -10 °C cell temperature)
Input voltage, MPP range	U_{PV}	96 V ... 200 V
Max. input current	I_{PVmax}	7 A
Max. input power	P_{DC}	670 W
Recommended generator power		750 W _p
All-pole isolator on the DC input side		DC plug connector
Overvoltage protection		Thermally monitored varistors
Voltage ripple	U_{PP}	< 10 % of the input voltage
Insulation protection		Ground fault monitoring (Riso > 1 MΩ)
Operating consumption		< 4 W (standby)
Reverse polarity protection		Short circuit diode

7.2.2 Grid connection data

Nominal output power	P_{ACnom}	600 W
Peak output power	P_{ACmax}	600 W
Nominal output current	I_{ACnom}	2.6 A
Harmonic distortion of output current (at $K_{Ugrid} < 2\%$, $P_{AC} > 0.5 P_{ACnom}$)	K_{IAC}	< 3 %
Short-circuit strength		Grid-side via current regulation
Operating range, grid voltage	U_{AC}	198 ... 260 V AC
Operating range, grid frequency	f_{AC}	49.8 ... 50.2 Hz
All-pole isolation on grid side		Independent disconnection device (MSD), redundant design
Phase shift angle (based on the current's fundamental frequency)	$\cos \phi$	1
Overvoltage category		III
Test voltage (50 Hz)		1.3 kV (1 s routine testing / 5 s type testing)
Test surge voltage		4 kV (serial interface: 6 kV)
Own consumption in night mode		0.1 W

7.3 Input voltage range 73 ... 150 V DC

7.3.1 PV generator connection data

Max. input open circuit voltage	U_{PV0}	250 V (based on -10 °C cell temperature)
Input voltage, MPP range	U_{PV}	73 V ... 150 V
Max. input current	I_{PVmax}	7 A
Max. input power	P_{DC}	510 W
Recommended generator power		600 Wp
All-pole isolator on the DC input side		DC plug connector
Overvoltage protection		Thermally monitored varistors
Voltage ripple	U_{PP}	< 10 % of the input voltage
Insulation protection		Ground fault monitoring (Riso > 1 M Ω)
Operating consumption		< 4 W (standby)
Reverse polarity protection		Short circuit diode

7.3.2 Grid connection data

Nominal output power	P_{ACnom}	460 W
Peak output power	P_{ACmax}	460 W
Nominal output current	I_{ACnom}	2 A
Harmonic distortion of output current (at $K_{Ugrid} < 2\%$, $P_{AC} > 0.5 P_{ACnom}$)	K_{AC}	< 3 %
Short-circuit strength		Grid-side via current regulation
Operating range, grid voltage	U_{AC}	198 ... 260 V AC
Operating range, grid frequency	f_{AC}	49.8 ... 50.2 Hz
All-pole isolation on grid side		Independent disconnection device (MSD), redundant design
Phase shift angle (based on the current's fundamental frequency)	$\cos \varphi$	1
Overvoltage category		III
Test voltage (50 Hz)		1.3 kV (1 s routine testing / 5 s type testing)
Test surge voltage		4 kV (serial interface: 6 kV)
Own consumption in night mode		0.1 W

7.4 Device description

For a detailed description of the device, see the operating instructions.

General data

Protection category per DIN EN 60529	IP65
Dimensions (w x h x d)	322 mm x 290 mm x 180 mm (approx.)
Weight	16 kg (approx.)

External interfaces

Data transmission over mains power line	Optional
Data transmission over separate data cable	Optional, RS232 / RS485, electrically separated
Wireless data transmission	Optional

Efficiency

Max. efficiency	η_{max}	93.4 %
European standard efficiency	η_{eu20}	92 %

The efficiency of the Sunny Boy 700 depends mainly on the input voltage of the connected PV strings. The lower the input voltage, the higher is the efficiency of the Sunny Boy 700.

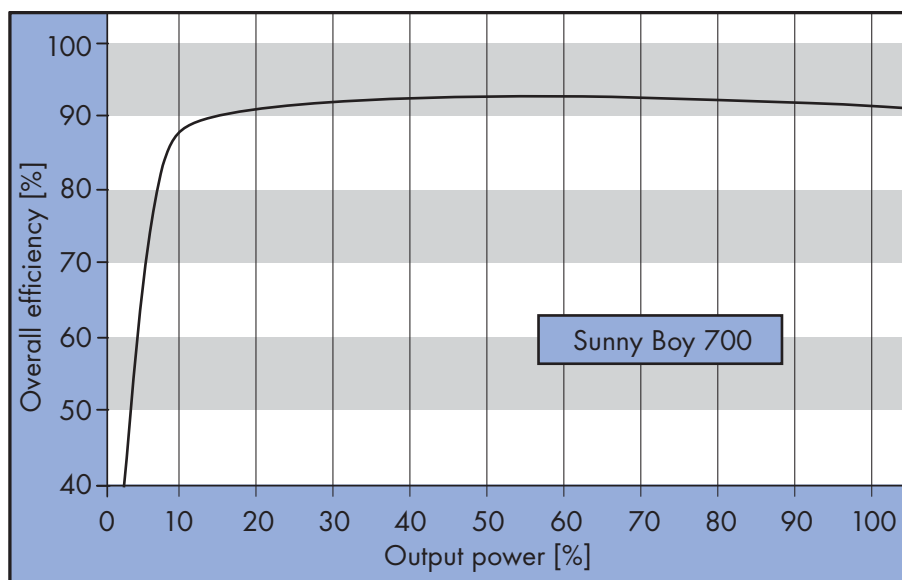

7.5 Operating parameters

Unauthorised changes to the operating parameters may result in:



- **Injury or accidents as a result of changing the internal safety routines in the Sunny Boy**
- **Voiding the Sunny Boy's operating approval certificate**
- **Voiding the Sunny Boy's guarantee**

Never change the parameters of your Sunny Boy without express authorization and instructions.

The parameters with a grey background are only visible when in installer mode.

Name	Unit	Value range	Factory setting
Betriebsart / Operating mode		MPP, IKonst, UKonst, Stopp, Turbine Mode, Insel Mode	MPP
Default			GER/ENS
dFac-Max	Hz/s	0.005 ... 4.0	0.5
dZac-Max	mOhm	0 ... 20000	350
E_Total	kWh	0 ... 200000	
Fac-Delta-	Hz	0 ... 4.5	0.19
Fac-Delta+	Hz	0 ... 4.5	0.19
h_Total	h	0 ... 200000	
I-NiTest / Testcurrent Zac	mA	0 ... 6000	4500/ 4000/ 3500
Speicherfunktion / Memory function		Default Parameter, Reset Betriebsdaten, Reset Fehler	none
Speicher/Storage		Permanent, volatile	Permanent
T-Start	s	5 ... 300	10
T-Stop	s	1 ... 3600	2
Uac-Min / Vac-Min	V	180 ... 300	198
Uac-Max / Vac-Max	V	180 ... 300	260
Upv-Start / Vpv-Start	V	125 ... 250/ 100 ... 200/ 75 ... 150	150/ 125/ 95
Usoll-Konst / Vconst-Setpoint	V	125 ... 330/ 100 ... 330/ 75 ... 330	275/ 275/ 275

The following parameters are displayed in the parameter list but cannot be changed:

Name	Unit	Value range	Description
Plimit	W	700/ 600/ 460	Upper limit for AC output power
SMA-SN			Serial number of the Sunny Boy
Software-BFR / Firmware BFR			Firmware version of the operation control unit (BFR)
Software-SRR / Firmware SRR			Firmware version of the current control unit (SRR)

8 Replacing the varistors

The Sunny Boy 700 is a complex high-technology device. As a result, the possibilities for fixing faults on site are limited to just a few items. Please don't try to carry out repairs other than those described here. Use the **SMA Technologie AG** 24-hour exchange service and repair service instead.

If the red LED on the status display glows continuously during operation, you should first of all make sure that there is no earth fault in the PV generator.

1. Disconnect the Sunny Boy 700 from the low voltage grid (pull out the AC plug or switch the line circuit breaker to its "off" position). Make sure the grid cannot be inadvertently reconnected.

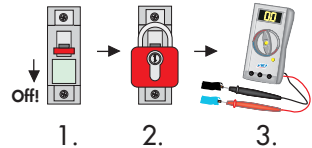

You must make sure that no voltage is present at the AC output before opening the Sunny Boy.

2. Disconnect the DC plug connectors for all strings. Make sure you note the order of the individual inverter inputs so you can put them back in the right place later!

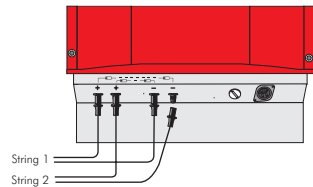

Disconnect the PV generators from the Sunny Boy.

3. Taking one DC plug connector at a time, measure the voltages between one DC plug connector of a string and earth potential. Pay attention to the safety warnings!

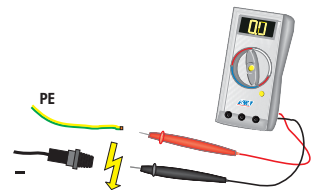

Measure the voltage between DC plug connectors and earth potential.

Caution! Dangerous high voltages may be present. Danger of death!



4. If the measured voltages are constant and if their total is roughly the same as the open circuit voltage of the string then there is a earth fault in this string. Its approximate location can be deduced from the relationships between the voltages.

5. Repeat points 3 and 4 for each string.
If you found a earth fault, it is probably not necessary to replace the varistors. Instead, make sure the ground fault is fixed. Generally the PV generator's installation engineer should be hired for this job. In this case continue as described under point 10, but without reconnecting the faulty string. Instead of reconnecting the string, protect its DC plug against accidental touch contact (e.g. by fitting the protective caps or using sufficient high-voltage insulating tape).

If you did not find any earth fault in the PV generators, it is likely that one of the thermally monitored varistors has lost its protective function. These components are wearing parts. Their functioning diminishes with age or following repeated responses as a result of overvoltages. You can now check these varistors in the following way, paying attention to the safety information in section 2 "Safety information" (page 9):

6. Remove the screws that secure the lid and remove the lid from the Sunny Boy 700. Disconnect the PE connection from the lid. Make sure that no voltage is present.
7. Using a continuity tester, check all the varistors to see if there is a conducting connection between connectors 2 and 3. If there isn't, then that varistor is not working. The positions of the varistors in the Sunny Boy 700 can be seen in section 3.1 "Unit description" (page 11).
8. Replace the varistor concerned with a new one as shown in the drawing to the right. Ensure the varistor is installed the right way round! If you do not receive a special tool for operating the terminal clamps with your replacement varistors, please contact SMA. As an alternative, the terminal contacts can be operated using a suitable screwdriver. Since the failure of one varistor is generally due to factors that affect all varistors in a similar way (temperature, age, inductive overvoltages), it is highly recommended that you replace both varistors, not just the one that is obviously defective. The varistors were specially manufactured for use in the Sunny Boy 700 and are not commercially available. They must be ordered directly from **SMA** Technologie AG (SMA order code: SB-TV1).

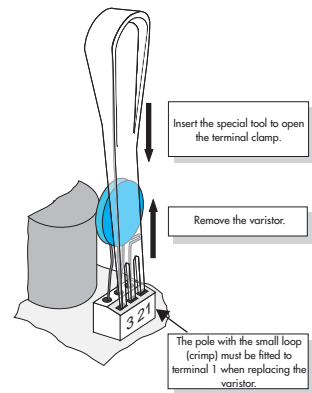

In case there are no spare varistors available the Sunny Boy 700 still can feed electricity into the grid. The input is not protected against overvoltages in this case. Replacement varistors should be obtained as soon as possible. In systems with a high risk of overvoltages, the Sunny Boy 700 should not be operated with defective varistors.



9. Reconnect the PE connection on the lid and close the Sunny Boy 700.
10. Connect up the faultless PV generator strings to the inverter.
11. Close off the unneeded DC input sockets using the protective caps supplied in the accessories kit.
12. Switch the line circuit breaker to the "on" position.
13. Now check whether the LED display on the Sunny Boy 700 indicates that the device is functioning correctly.

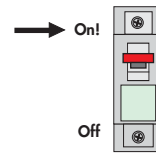
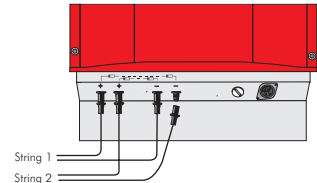

If no earth fault and no defective varistor were found, there is probably a fault in the Sunny Boy. In this case, contact the SMA hotline to discuss what to do next.

9 Rating for a line circuit breaker

Example for the thermal rating for a line circuit breaker in a photovoltaic electrical power unit operated in parallel with the low-voltage grid



We assume a PV system with 9 Sunny Boy 700 inverters, with three inverters per phase.

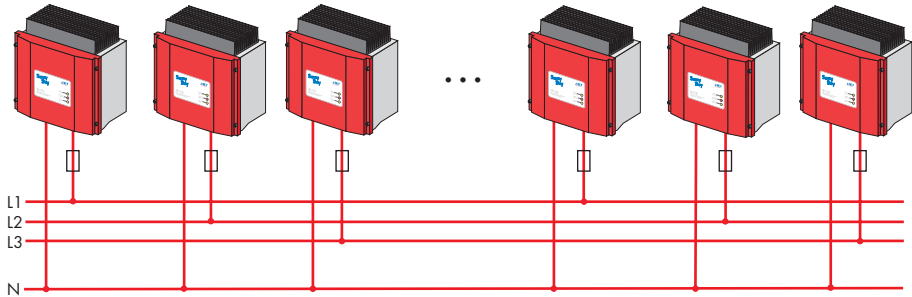

Required technical information for the inverters used:

- Maximum output current = 3.5 A
- Maximum permissible fuse protection for the inverter = 16 A

The choice of cable together with the way it is routed, ambient temperatures and other underlying conditions limit the maximum fuse protection for the cable.

- In our example we assume that the chosen cable (2.5 mm²) is ideally routed and can take a nominal current of 11 A.

Selecting a line circuit breaker:

- The maximum possible nominal current for the cable used and the maximum possible fuse protection for the inverter now limit the maximum possible nominal current for the line circuit breaker.
- In our example, 10 A is possible.

However, the thermal suitability of the line circuit breaker still needs to be checked.

When selecting line circuit breakers, a number of load factors need to be taken into account. These can be found in the respective data sheets.



Example for the thermal selection of a 10 A line circuit breaker with B sensitivity with no gap between the circuit breakers:

For example, one manufacturer's circuit breaker may be designed for an ambient temperature of 50 °C.

Load factors according to data sheet specifications:

- Reduction through permanent load >1h = 0.9¹
- Reduction when 9 circuit breakers are arranged side-by-side without gaps = 0.77²
- Increase in nominal current as a result of ambient temperatures of 40 °C in the circuit breaker panel = 1.07³

Result:

The nominal load current for the line circuit breaker is calculated as:

$$I_{bn} = 10 \text{ A} \times 0.9 \times 0.77 \times 1.07 = 7.4 \text{ A}$$

-
1. Permanent loads of longer than 1 hour are possible in photovoltaics.
 2. When only one circuit breaker is used, this factor = 1
 3. Because the circuit breakers are rated for 50 °C

Summary:

The selected line circuit breaker can be used in our example case since the maximum current-carrying capacity for fault-free operation is higher than the maximum output current of the inverter used. **It will trip under rated operating conditions!**

If the calculated current-carrying capacity of the circuit breaker had been lower than the maximum output current from the inverter, the following solution might have been used:

By spacing the circuit breakers at an interval of 8 mm, the reduction factor would be 0.98 instead of 0.77. As a result, the maximum current-carrying capacity would increase to 9.4 A.

As well as the thermal rating of the circuit breakers and all other factors as specified in section "Rating for a line circuit breaker in a photovoltaic electrical power unit operated in parallel with the low-voltage grid" (page 16), of course the applicable DIN VDE standards¹ also need to be taken into account. The main ones that apply here are:

- DIN VDE 0100; part 410
- DIN VDE 0100; part 430
- DIN VDE 0298; part 4

In special applications the relevant standards must be followed.

1. The standards mentioned above are to be only used as a guideline for your installation. They apply for installations in Germany. Please note that other standards will apply for different countries throughout the world.

10 Contact

If you have any questions or technical problems concerning the Sunny Boy 700, please contact our hotline. Please have the following information available when you contact SMA:

- Inverter type
- Type and number of connected modules
- Communication method
- Serial number of the Sunny Boy



Address:

SMA Technologie AG
Hannoversche Strasse 1 - 5
34266 Niestetal
Germany

Tel.:+49 (0)561 95 22 - 499
Fax:+49 (0)561 95 22 - 4699
hotline@SMA.de
www.SMA.de

SMA Technologie AG

www.SMA.de

Hannoversche Straße 1-5

34266 Niestetal

Germany

Tel. +49 561 9522 0

info@SMA.de



SMA Solartechnology China

International Metro Center,
Building A, City Square No. Jia 3,
Shilipu Road, Changyang District
100025 Beijing, P.R. China
Tel. +86 10 65 58 78 15
www.SMA-CHINA.com

Vertrieb SMA Italien

Via Lorenzo Valla, 16
20141 Milano
Italy
Tel. +39 02 847421

SMA America, Inc.

12438 Loma Rica Drive, Unit C
Grass Valley, CA 95945, USA
Tel. +1 530 273 4895
www.SMA-AMERICA.com

Vertrieb SMA Spanien

Balmes, 297
08006 Barcelona
Spain
Tel. +34 639 403683

Innovation in Systemtechnik
für den Erfolg der Photovoltaik

