

# Sunny Boy SB 700



## The string inverter



Professional inverter even for small PV-plants

3 different input voltage ranges

SMA grid guard® 2:  
Automatic disconnection

Diagnosis and communication via Powerline Communication, radio transmission or via data cable (RS232 or RS485)

Extended temperature range  
-25 °C to +60 °C

For outdoor and indoor installation

Today, the string technology developed by SMA is considered to be the state of the art for solar power systems. Subdividing the solar generator into several independent module strings, with one inverter assigned to each, leads to a significant reduction in installation work and in costs.

With its configurable input voltage range, the Sunny Boy SB 700 can be adjusted to individual system requirements in just a few simple steps. This means that even small system sizes can be implemented in line with the latest standards. At the same time the Sunny Boy SB 700 uses innovative technologies to ensure the maximum energy yield from the solar power system as a whole.

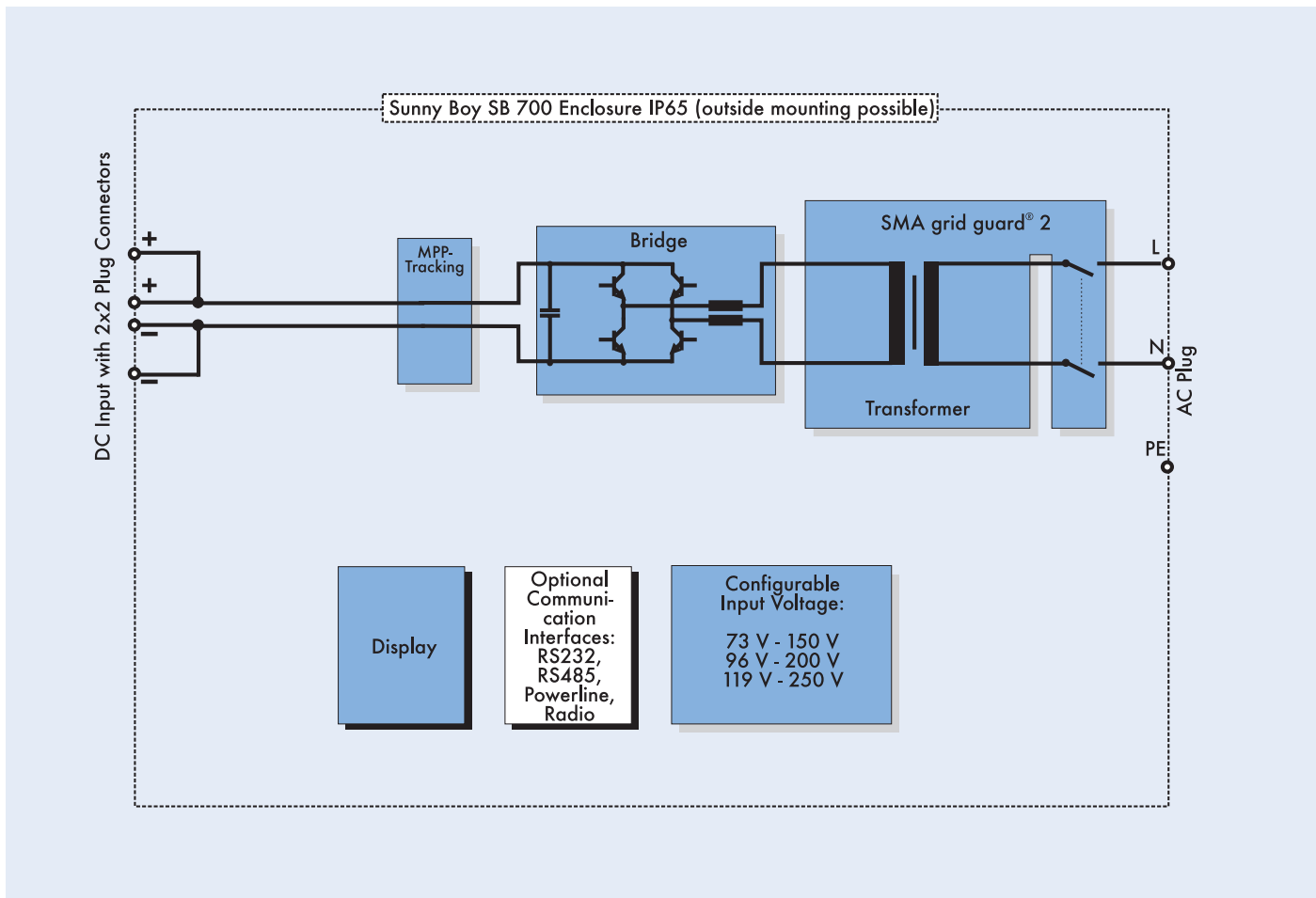

Schematic diagram of the Sunny Boy SB 700

## Technical Data

	SB 700 (73 to 150 V)	SB 700 (96 to 200 V)	SB 700 (119 to 250 V)
<b>Input</b>			
Max. DC power ( $P_{DC, max}$ )	510 W	670 W	780 W
Max. DC voltage ( $U_{DC, max}$ )	250 V	250 V	250 V
PV-voltage range, MPPT ( $U_{PV}$ )	73 V - 150 V	96 V - 200 V	119 V - 250 V
Max. input current ( $I_{PV, max}$ )	7 A	7 A	7 A
DC voltage ripple ( $U_{pp}$ )	< 10 %	< 10 %	< 10 %
Max. number of strings (parallel)	2	2	2
DC disconnection	Snap cable connectors	Snap cable connectors	Snap cable connectors
Thermally monitored varistors	yes	yes	yes
Ground fault monitoring	yes	yes	yes
Pole confusion protection	Short circuit diode	Short circuit diode	Short circuit diode
<b>Output</b>			
Max. AC power ( $P_{AC, max}$ )	460 W	600 W	700 W
Nominal AC power ( $P_{AC, nom}$ )	460 W	600 W	700 W
THD of grid current	< 3 %	< 3 %	< 3 %
Nominal AC voltage ( $U_{AC, nom}$ )	220 V - 240 V	220 V - 240 V	220 V - 240 V
Nominal AC frequency ( $f_{AC, nom}$ )	50 Hz / 60 Hz	50 Hz / 60 Hz	50 Hz / 60 Hz
Phase shift ( $\cos \varphi$ )	1	1	1
Short circuit proof	yes, current control	yes, current control	yes, current control
Connection to utility	AC Plug	AC Plug	AC Plug
<b>Efficiency</b>			
Max. Efficiency	93.4 %	93.4 %	93.4 %
Euro-eta	92 %	92 %	92 %
<b>Enclosure</b>			
accord. to DIN EN 60529	IP65	IP65	IP65
<b>Mechanical Data</b>			
Width / height / depth in mm	322 / 290 / 180	322 / 290 / 180	322 / 290 / 180
Weight	16 kg	16 kg	16 kg