



# Sunny Boy SB 1100

## String Inverter Sunny Boy SB 1100





# Table of Contents

<b>1</b>	<b>Explanation of Symbols used in this Document . .</b>	<b>5</b>
<b>2</b>	<b>Foreword . . . . .</b>	<b>7</b>
<b>3</b>	<b>Safety instructions . . . . .</b>	<b>9</b>
<b>4</b>	<b>Overview . . . . .</b>	<b>11</b>
4.1	Unit description . . . . .	11
4.2	External dimensions . . . . .	12
<b>5</b>	<b>Installation requirements . . . . .</b>	<b>13</b>
5.1	Installation site requirements . . . . .	13
5.2	PV generator requirements. . . . .	15
5.3	Low voltage grid (AC). . . . .	15
<b>6</b>	<b>Installation . . . . .</b>	<b>19</b>
6.1	Mounting the unit . . . . .	19
6.2	Electrical installation . . . . .	20
6.2.1	Connecting the AC output. . . . .	22
6.2.2	PV string (DC) connection . . . . .	27
6.3	Commissioning. . . . .	28
<b>7</b>	<b>Opening and closing the Sunny Boy . . . . .</b>	<b>31</b>
7.1	Opening the Sunny Boy . . . . .	31
7.2	Closing the Sunny Boy . . . . .	31
<b>8</b>	<b>Technical data . . . . .</b>	<b>33</b>
8.1	PV generator connection data . . . . .	33
8.2	Grid connection data . . . . .	34
8.3	Device description . . . . .	35
8.4	Operating parameters. . . . .	36
8.4.1	Explanation of the operating parameters . . . . .	36
8.4.2	Parameter settings for Germany. . . . .	38
8.4.3	Country-specific parameter settings . . . . .	40

8.4.4	Non-modifiable parameters. . . . .	40
8.5	Certificates. . . . .	41
8.5.1	CE declaration of conformity. . . . .	41
8.5.2	SMA grid guard certificate . . . . .	42
<b>9</b>	<b>Replacing the varistors. . . . .</b>	<b>43</b>
<b>10</b>	<b>Rating for a line circuit breaker . . . . .</b>	<b>47</b>
<b>11</b>	<b>The communications interface . . . . .</b>	<b>51</b>
11.1	Connection of the interface . . . . .	52
11.1.1	Jumper functions . . . . .	53
<b>12</b>	<b>Contact. . . . .</b>	<b>55</b>

# 1 Explanation of Symbols used in this Document

To enable optimal usage of this manual and safe operation of the device during installation, operation and maintenance routines, please note the following description of symbols:

This symbol indicates an example.



*This symbol identifies a notice where failure to follow the advice will make the procedure or operation more difficult.*



**This symbol identifies a warning, which indicates a fact or feature which, if ignored, can cause serious damage to the device.**





## 2 Foreword

### Caution!

**The Sunny Boy may only be installed by trained specialists. Installers must be approved by the local energy supplier. Please carefully read this installation manual. All prescribed safety regulations, the technical connection requirements of the local energy supplier and all applicable provisions must be followed.**



*The Sunny Boy SB 1100 is equipped with SMA grid guard. This is a type of independent disconnection device. It ensures that the Sunny Boy SB 1100 complies with the VDEW (Verband der Elektrizitätswirtschaft – German Electricity Industry Association) regulations for the connection and parallel operation of electrical power units to the low-voltage grid of the electricity supply company and with DIN VDE 0126-1-1, which forms a part of these regulations.*



This installation manual is intended solely for qualified electricians. Its aim is to help install and set up SMA Sunny Boy SB 1100 inverters quickly and correctly.

For detailed information on troubleshooting and on how to use the Sunny Boy and the various communications options, please see the operating instructions.

"Sunny Design" helps you design the system and check string size taking the relevant inverter into consideration. Further information on Sunny Design is available at [www.SMA.de](http://www.SMA.de).

If you require further information, call the Sunny Boy hotline on the following number:

+49 561 95 22 - 499



### 3 Safety instructions

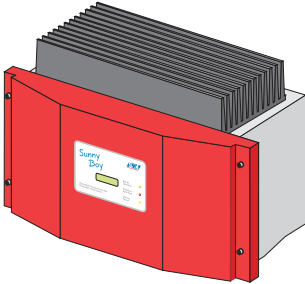

#### Caution! Overvoltage!

Check the system design using the "Sunny Design" design tool ([www.SMA.de](http://www.SMA.de)) or by calling the Sunny Boy Hotline. Overvoltages may lead to the destruction of the Sunny Boy SB 1100.



#### Warning! High voltage!

Work on the Sunny Boy with the cover removed must be carried out by a qualified electrician. High contact voltages are present in the device. Before working on the Sunny Boy with the cover removed, the AC and DC voltages must be disconnected from the Sunny Boy and the capacitors must be discharged.



The Sunny Boy must be disconnected from the mains grid and precautions must be taken to prevent the grid being reconnected. In addition, the connections to the PV generator must be disconnected.

After isolating the AC and DC voltage, you must wait approx. 30 minutes for the capacitors in the Sunny Boy to discharge. Only then is it safe to open the unit by removing the cover. You must also make sure that no voltage is present in the device.

#### Caution! Electrostatic charge!

When working on the Sunny Boy SB 1100 and handling the components, remember to observe all ESD safety regulations. Electronic components are susceptible to electrostatic discharge. Discharge any electrostatic charge by touching the grounded enclosure before handling any electronic component.





# 4 Overview

## 4.1 Unit description

The following diagram gives a schematic overview of the various components and connection points inside the Sunny Boy SB 1100 with the cover removed:

Varistors, page 43

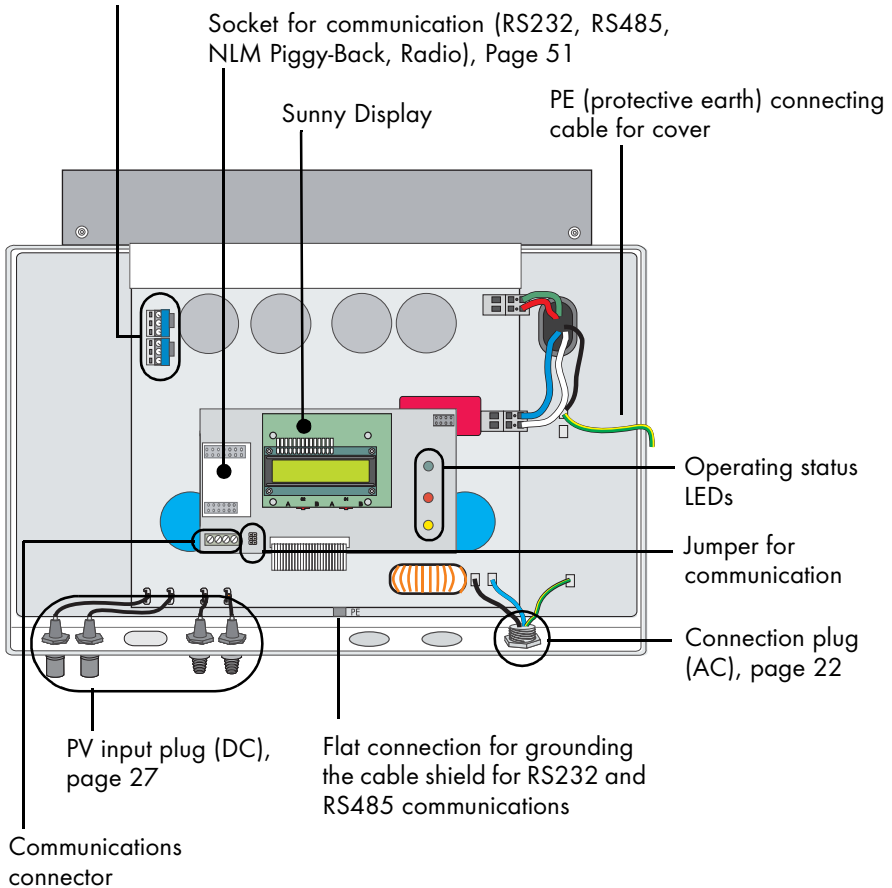

## 4.2 External dimensions

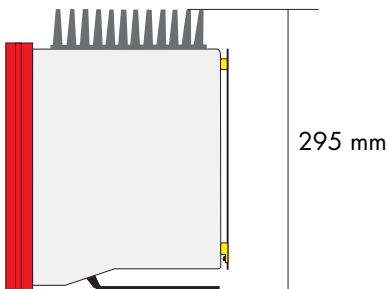
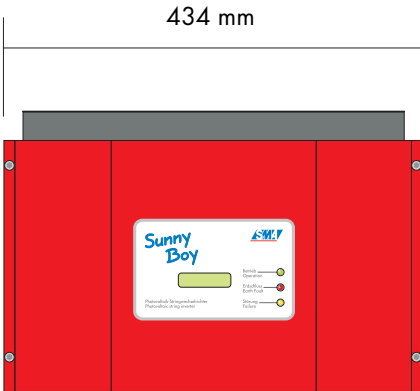
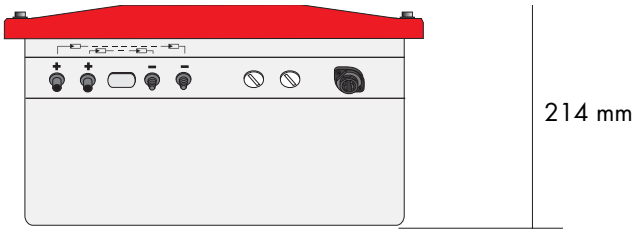

## 5 Installation requirements

Check that all of the conditions listed below are met before installing and setting up the Sunny Boy.

### 5.1 Installation site requirements

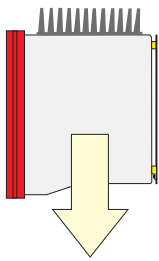

22 kg

The Sunny Boy SB 1100 weighs 22 kg. Take this weight into account when choosing the installation site and method of installation.

The ambient temperature must not be outside the  $-25^{\circ}\text{C}$  to  $+60^{\circ}\text{C}$  range.



The Sunny Boy SB 1100 should be installed in a place where it is not exposed to direct sunlight. An increased ambient temperature can reduce the yield of the PV system.

The Sunny Boy is designed to be mounted on a vertical wall. If absolutely necessary, however, the Sunny Boy can be installed tilted back at a maximum angle of  $45^{\circ}$ . For an optimum energy yield and the most convenient operation, vertical installation at eye-level is preferable. If installing the unit outdoors, make sure that it is not slanting forward. The rear panel is designed such that the Sunny Boy SB 1100 is tilting slightly backward on a perfectly vertical wall.

We advise against installing the unit in a horizontal position outdoors.

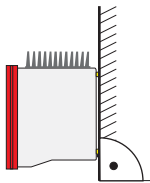

Install the inverter vertically or tilting backward.

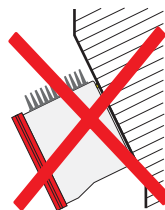
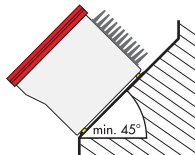

Never install the inverter horizontally or so that it tilts forward.



**When choosing the installation site, be sure to note the following:**



**Warning! High voltage!**

Unintentionally pulling out the DC plug connector under load can damage the plug and result in bodily injury or death! Install the Sunny Boy in such a way that it is not possible (e.g. for children) to unplug the DC plug connector unintentionally.



**Warning! Risk of burns!**

The temperature of the Sunny Boy, especially the heat sink, and the temperature of the individual components in the housing can exceed 60 °C. Touching could result in burns!



**Warning!**

Do not install the Sunny Boy on flammable construction materials, in areas where highly inflammable materials are stored or in potentially explosive environments!

When choosing the installation site, ensure there is enough space for heat to dissipate. Under normal conditions, the following guidelines should be applied for the space to be kept clear around the Sunny Boy SB 1100:

	Minimum clearance
Sides	20 cm
Top	20 cm
Underneath	20 cm
Front	5 cm

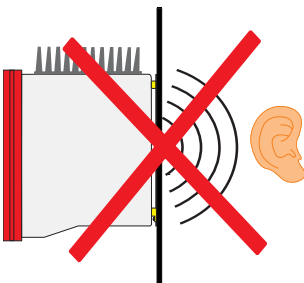
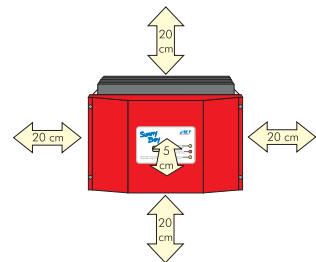

In domestic installations, the unit should not be mounted on plasterboard walls or similar as otherwise audible vibrations are likely to result.

We recommend securing the unit to a solid surface. The Sunny Boy makes noises when in use which can, in the domestic installation, be seen as a nuisance.

## 5.2 PV generator requirements

The Sunny Boy SB 1100 is designed to be connected to up to two strings (PV modules wired in series) having a homogenous structure (modules of the same type, identical orientation and tilt).

"Sunny Design" helps you design the system and check string size taking the relevant inverter into consideration. Further information on "Sunny Design" is available at [www.SMA.de](http://www.SMA.de).

The unit has four DC plug connectors (two for each string) for connecting the PV generators. The connecting cables from the PV generators must also be fitted with this type of plug connector. A pre-assembled set for connecting the free cable ends from a string is available as an optional accessory. The SMA order codes for the various connectors are as follows:

- Multi-Contact 3mm: "SWR-MC"
- Multi-Contact 4mm: "MC-SET"
- Tyco: "TYCO-SET"

Limit values for DC input	
Max. voltage	400 V (DC)
Max. input current	10 A (DC)

## 5.3 Low voltage grid (AC)

The Sunny Boy must have a three-conductor connection to the mains grid (live (L), neutral (N), protective earth (PE)).

The grid connection terminals on the AC connection socket included in the accessories kit can take wires with a cross-section of up to 2.5 mm<sup>2</sup>. The accessories kit also contains a PG13.5 AC connection socket for connecting cables with a cable diameter between 9 mm and 13.5 mm, while the PG16 connection socket is used for cables with cable diameters from 13.5 mm up to a maximum of 17 mm. For detailed instructions, see sections „Connecting the AC output with PG13.5“ (Seite 23) and „Connecting the AC plug with PG16“ (Seite 25).

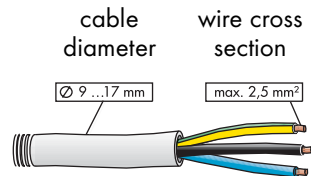

**We recommend using a 16 A line circuit breaker to protect the power circuit. No loads should be connected to this power circuit.**



## Rating for a line circuit breaker in a photovoltaic electrical power unit operated in parallel with the low-voltage grid

Various factors should be taken into account when selecting line circuit breakers. These include, for example:

- The type of cable used (conductor material and insulation)
- Ambient temperatures affect the cables (higher temperatures result in a reduced maximum current load)
- Method of routing the cable (reduces the ampacity of the conductor)
- Bundling cables together (reduces the ampacity of the conductor)
- Loop impedance  $[Z]$  (in the event of a body contact this limits the current that can flow and therefore determines the response behavior of the circuit breaker)
- Sufficient distance between the circuit breakers so as to avoid undue heating (heat can trigger the circuit breakers early).
- Selectivity
- Protection class of the connected load (VDE 0100, part 410, "Protection against electric shock")



Refer to section 10 „Rating for a line circuit breaker“ (Seite 47).

The following standards should be followed in all cases:

- DIN VDE 0298-4 (Cable routing and current-carrying capacity)
- DIN VDE 0100; part 430 (Protective measures; protection of cable and cords against overcurrent)
- DIN VDE 0100; part 410 (Protective measures; protection against electric shock)

AC cable system impedance should not exceed 1 ohm. This is necessary, amongst other things, for the correct operation of impedance observation. In addition, we recommend dimensioning the conductor cross-section so that line losses do not exceed 1 % at the nominal power. Line losses depending on the cable length and cross-section are shown in the graph below. Multi-wire cables with copper forward and return conductors are used.

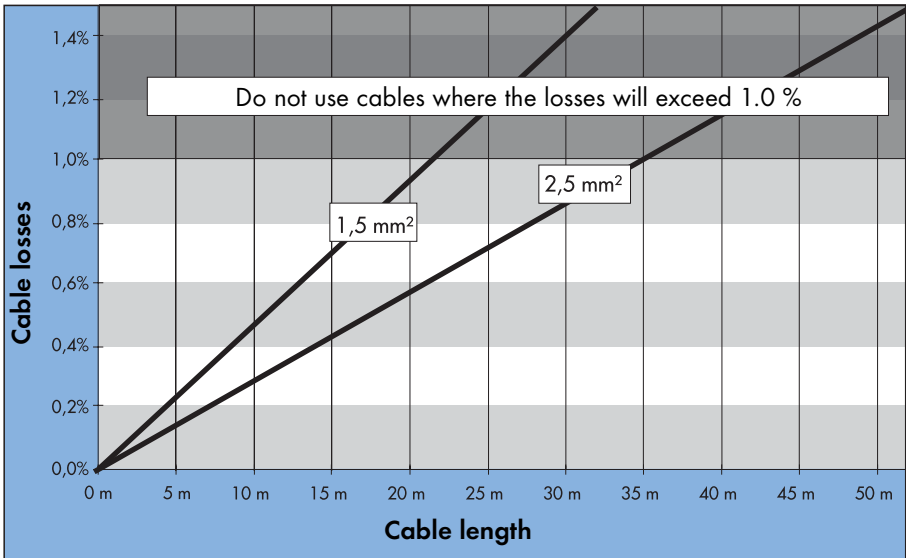

The maximum cable lengths for the different cable cross-sections are as follows:

<b>Conductor cross-section</b>	1.5 mm <sup>2</sup>	2.5 mm <sup>2</sup>
<b>Max. length</b>	21 m	35 m

When connecting the inverter to the public grid, follow the connection requirements of the local grid operator. The Sunny Mini Central is designed for operation on 220 V - 240 V grids. Additionally, it is equipped with an automatic grid frequency identifier and can thus be connected to a 50 or 60 Hz system without further parameterization.

	<b>Limit values for AC output</b>
Voltage range (per DIN VDE 0126-1-1)	198 V ... 253 V
Frequency range (per DIN VDE 0126-1-1)	47.55 Hz ... 50.2 Hz
Voltage range (extended operating range)	180 V ... 265 V
Frequency range (extended operating range)	45.5 Hz ... 54.5 Hz

The Sunny Boy SB 1100 is fitted with an automatic grid frequency identifier. Therefore, it can be connected to a 50 or 60 Hz system without further parameterization. Always follow the grid operator's instructions.

## 6 Installation

### 6.1 Mounting the unit

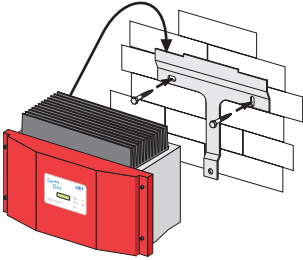

To make the job easier, we recommend you use the supplied wall bracket to mount the Sunny Boy SB 1100. For vertical installation on solid concrete or block walls, for example, you can fit the bracket using 8 mm x 50 mm hexagon bolts to DIN 571 standard, stainless steel type, and with wall plugs type SX10.

When selecting the mounting materials, be sure to take into account the weight of the Sunny Boy SB 1100 (22 kg).

1. Fit the wall bracket (1). To mark the positions to drill the holes, you can use the wall bracket as a drilling template.
2. Now hook the Sunny Boy SB 1100 onto the wall bracket (2) at its upper mounting plate so that it cannot be moved sideways.
3. Fix the Sunny Boy SB 1100 onto its bracket by screwing the supplied M6x10 bolt into the central threaded hole at the bottom of the bracket (3).
4. Make sure the Sunny Boy SB 1100 is positioned securely on the bracket.

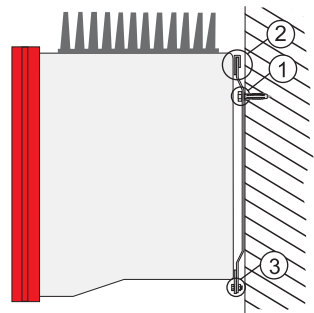

## 6.2 Electrical installation



**Caution!**

**Make sure to check the polarity of the strings before connecting them!**

The complete wiring for a Sunny Boy SB 1100 is shown schematically in the following diagram:

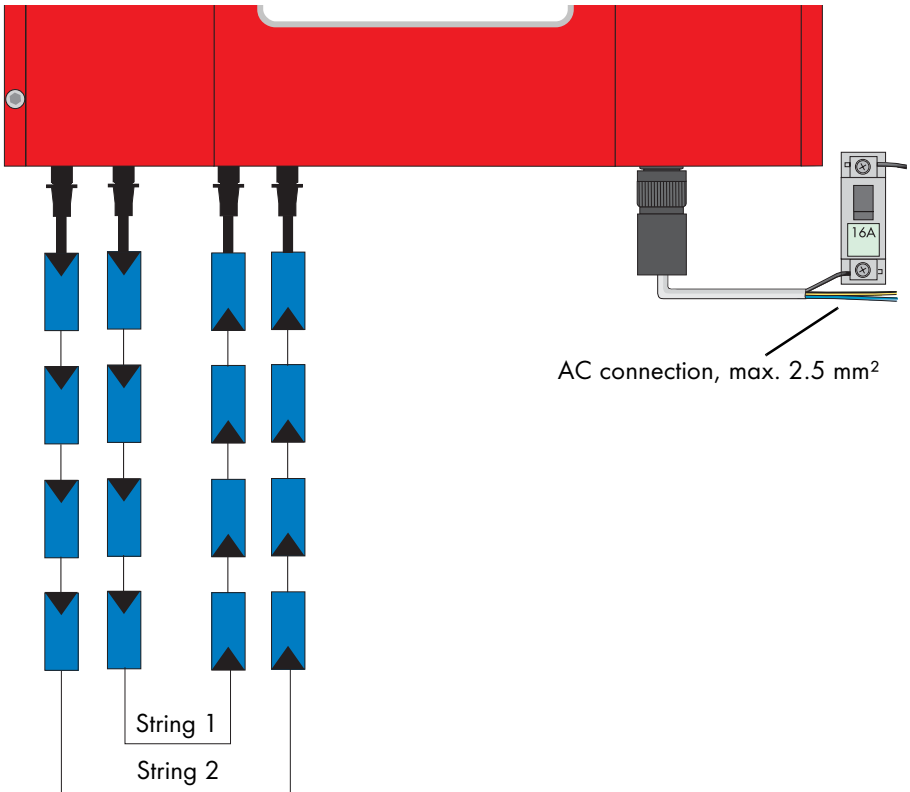

### Ansicht von unten

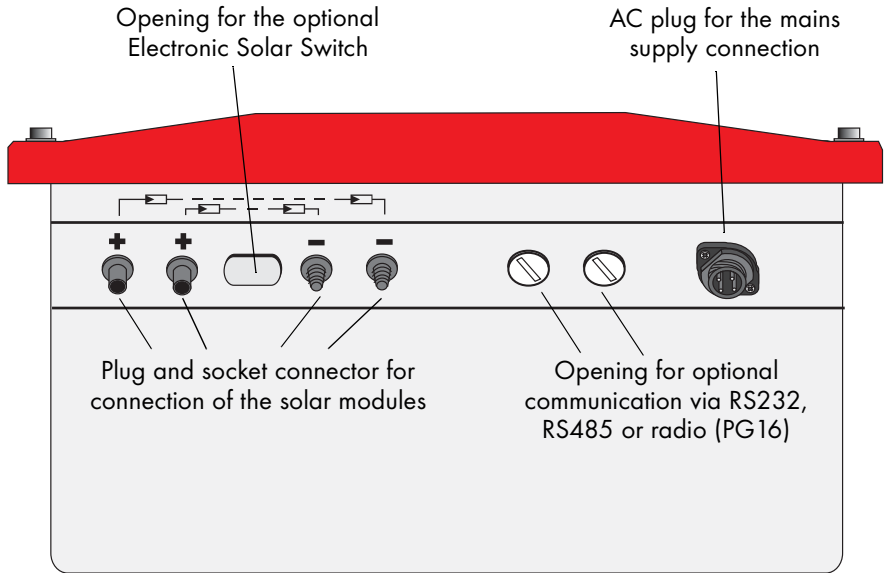

## 6.2.1 Connecting the AC output

### Caution!

Before you connect the mains cable to the AC connection socket, make sure that no voltage is present in the cable.



A round plug connector system is used, which allows various cable diameters to be used in the cable outlet. For this reason, the accessories kit includes a PG13.5 pressure screw and a PG16 pressure screw. Check which screw fitting is the right one for your AC cable.

To connect up the AC output, follow these steps:

1. Check the grid voltage. If this is higher than 253 V, the Sunny Boy SB 1100 will not be fully operational. In this case, contact the local grid operator for assistance.
2. Isolate the grid connection (switch the line circuit breaker to its "off" position), make sure it cannot be switched back on, and test to make sure no voltage is present.

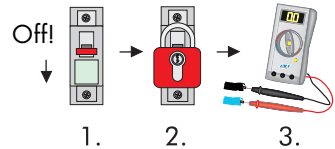

3. Now take the AC connection socket parts from the accessories kit and connect up the cable, with shielding and insulation stripped, as described on the following pages:

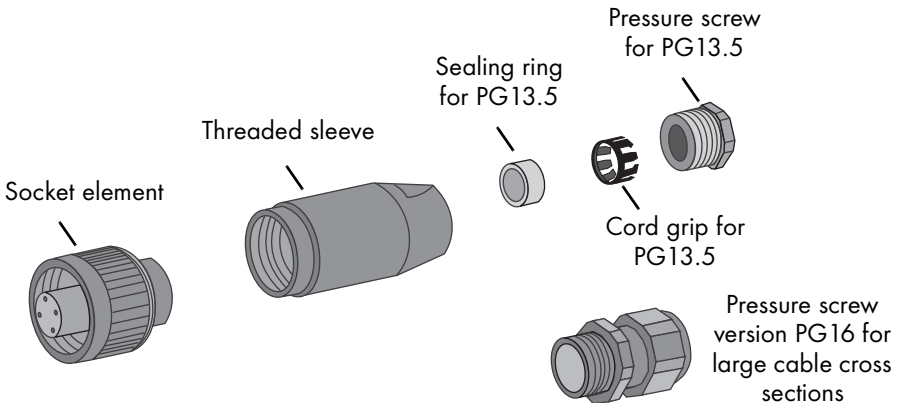

## Connecting the AC output with PG13.5

To connect a cable with a maximum cross-section of 13.5 mm<sup>2</sup>, proceed as follows.

1. Press the sealing ring into the cord grip.

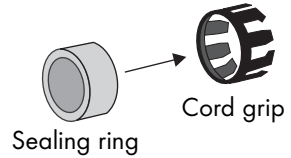

2. Now slide the pressure screw over the cable first of all, followed by the cord grip with the sealing ring in it. Now slide the threaded sleeve over the cable.

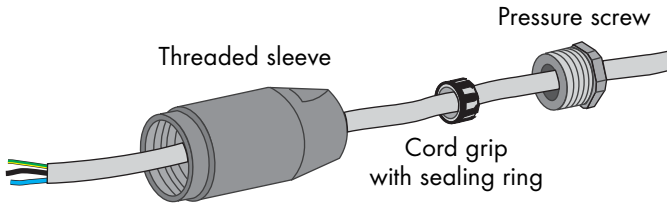

3. Now connect the individual conductors to the socket element in sequence.

- Protective earth PE (green/yellow) to the screw terminal with the earth sign. Make sure that the PE earth wire is longer than the N and L connected wires.
- Neutral conductor N (blue) to screw terminal 1.
- Live L (brown or black) to screw terminal 2.
- Terminal 3 remains unused.

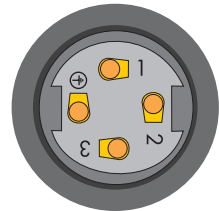

4. Make sure the wires are securely connected.

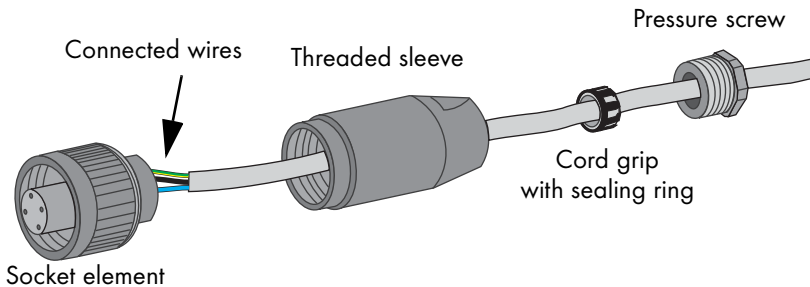

5. Now screw the threaded sleeve onto the socket element and tighten it.

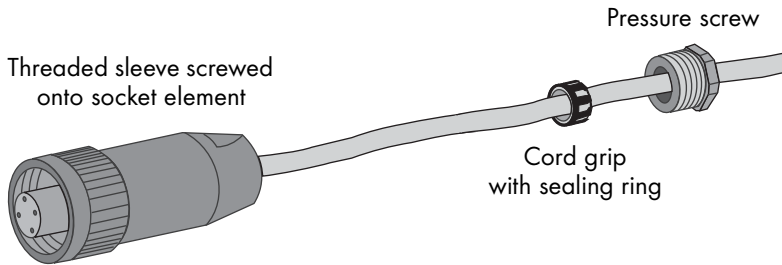

6. Now screw the pressure screw into the threaded sleeve and tighten it. The cord grip with the sealing ring is pressed into the threaded sleeve and can no longer be seen.

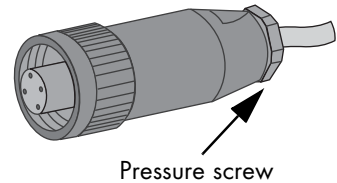

The AC connecting socket is now fully assembled.

If you are not going to connect up the Sunny Boy immediately, close off the socket element using the cap supplied in the accessories kit.

If the Sunny Boy is already installed, you can now connect up the fully assembled AC connection socket to the flange plug on the Sunny Boy. To do this, remove the protective cap from the flange plug on the Sunny Boy. Firmly tighten the threaded ring on the AC connecting socket to the flange plug to seal the connection and secure it.

### Caution!

**Do not switch the line circuit breaker on yet! The Sunny Boy SB 1100 may only be connected to the AC grid once the PV strings are connected and the device is securely closed.**



## Connecting the AC plug with PG16

To connect a cable with a cross-section between 13.5 mm<sup>2</sup> and 16 mm<sup>2</sup>, proceed as follows.

1. First of all, slide the pressure screw with the PG16 screw fitting onto the cable. Now slide the threaded sleeve over the cable.

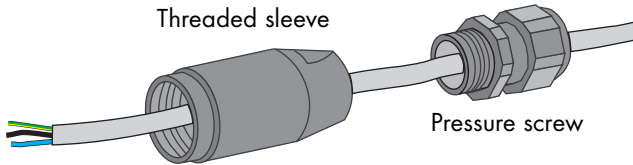

2. Now connect the individual conductors to the socket element in sequence.

- Protective earth PE (green/yellow) to the screw terminal with the earth sign. Make sure that the PE earth wire is longer than the N and L connected wires.
- Neutral conductor N (blue) to screw terminal 1.
- Live L (brown or black) to screw terminal 2.
- Terminal 3 remains unused.

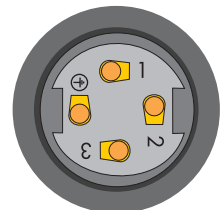

Terminals in the socket element

3. Make sure the wires are securely connected.

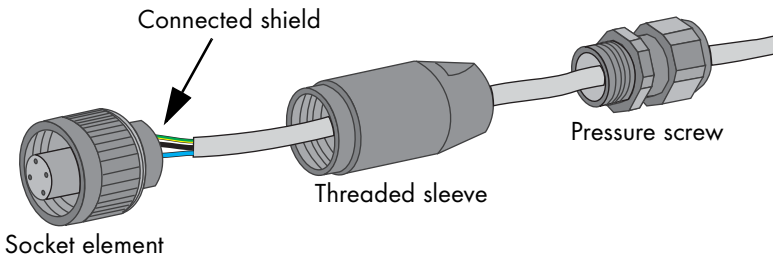

4. Now screw the threaded sleeve onto the socket element and tighten it.

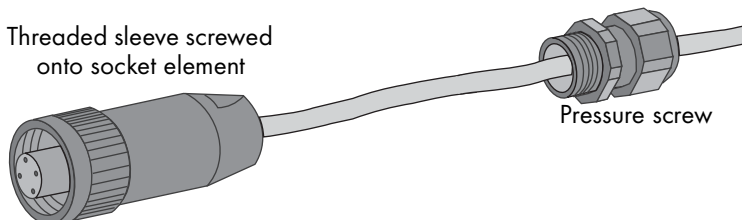

5. Now screw the pressure screw into the threaded sleeve and tighten it.
6. Firmly tighten the screw fitting against the seal and strain relief.

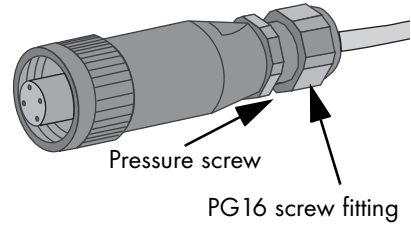

The AC connecting socket is now fully assembled.

If you are not going to connect up the Sunny Boy immediately, close off the socket element using the cap supplied in the accessories kit.

If the Sunny Boy is already installed, you can now connect up the fully assembled AC connection socket to the flange plug on the Sunny Boy. To do this, remove the protective cap from the flange plug on the Sunny Boy. Firmly tighten the threaded ring on the AC connecting socket to the flange plug to seal the connection and secure it.

### Caution!

**Do not switch the line circuit breaker on yet! The Sunny Boy SB 1100 may only be connected to the AC grid once the PV strings are connected and the device is securely closed.**



## 6.2.2 PV string (DC) connection

To connect up the input, follow these steps:

1. Make sure the PV generator connectors have the right polarity and do not exceed the maximum string voltage of 400 V (DC). See also section 5.2 „PV generator requirements“ (Seite 15).

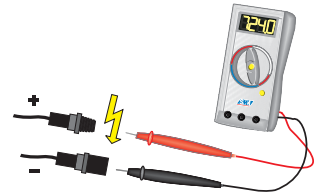

### Warning!

**Dangerous high voltages may be present. Danger of death!**

2. Taking one DC plug connector at a time, measure the direct current voltage between one DC plug connector of a string and earth potential.
3. If the measured voltages are constant and if their total is roughly the same as the open circuit voltage of the string, then there is a ground fault in this string. Its approximate location can be deduced from the relationships between the voltages.

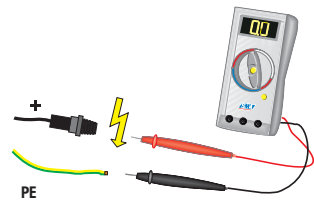

### Caution!

**Do not connect strings to the Sunny Boy SB 1100 that contain a ground fault until you have fixed the earth fault in the PV generator.**

4. Repeat points 2 and 3 for each string.
5. Connect up the faultless PV generator strings to the inverter.
6. Close the unnecessary DC input sockets with the caps included in the delivery.

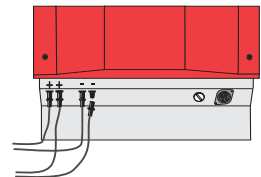

## 6.3 Commissioning

You can start up the Sunny Boy SB 1100 when

- The housing's cover is securely screwed shut
- The AC (mains) cable is connected correctly
- The DC cables (PV strings) are fully connected and the unused DC plug connectors on the bottom of the housing are closed using the protective caps

### How to start up the inverter

1. First of all, switch the line circuit breaker to the "on" position.

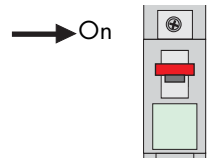

2. Now look at the LED display and consult the table on the following page to check whether the Sunny Boy SB 1100 is in a fault-free and expedient operating mode. Once the inverter is in a fault-free operating status, startup has successfully completed.

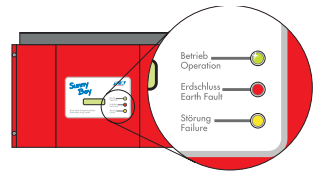

### Caution!

**If the bottom yellow LED flashes four times at intervals of one second, the grid voltage and the PV generator must be disconnected from the Sunny Boy SB 1100 immediately! There is a risk of damage to the inverter resulting from excessive DC input voltage.**



Check the string voltages again to make sure they are within the limits stated in section 5.2 „PV generator requirements“ (Seite 15). If the string voltages are too high, the PV generator's planner/installer should be called upon for assistance.

If despite checking the string voltages the LED signal occurs again when the PV generator is connected to the Sunny Boy SB 1100, disconnect the PV generator from the Sunny Boy again and contact **SMA Technologie AG** (see section 12 „Contact“ (Seite 55)).

Green	Red	Yellow	Status
Illuminates continuously	Is not illuminated	Is not illuminated	OK (working mode)
	Illuminates continuously	Is not illuminated	Fault
		Illuminates continuously	OK (initialization)
Flashes quickly (3x per second)	Is not illuminated	Is not illuminated	OK (stop)
	Illuminates continuously	Is not illuminated	Fault
Flashes slowly (1x per second)	Is not illuminated	Is not illuminated	OK (waiting, grid monitoring)
	Illuminates continuously	Is not illuminated	Fault
Briefly goes out (approx. 1x per second)	Is not illuminated	Is not illuminated	OK (derating)
	Illuminates continuously	Is not illuminated	Fault
Is not illuminated	Is not illuminated	Is not illuminated	OK (night shutdown)
		Illuminating/flashing	Fault
	Illuminates continuously	Is not illuminated	Fault
		Illuminating/flashing	Fault

For a detailed description of the fault messages and their causes, see the operating instructions.



## 7 Opening and closing the Sunny Boy

### Caution!

If you need to open the device for whatever reason, please pay attention to section 3 „Safety instructions“ (Seite 9).



### 7.1 Opening the Sunny Boy

#### Caution!

Follow the sequence below under all circumstances.



1. Switch the line circuit breaker to the "off" position.
2. Disconnect the PV generator from the Sunny Boy SB 1100.
- 3. Wait 30 minutes!**
4. Remove the four screws from the housing cover and pull the cover forward smoothly. Remove the PE connection from the cover. Loosen the locking on the PE connectors on the cover when you remove them.

### 7.2 Closing the Sunny Boy

#### Caution!

Follow the sequence below under all circumstances.



1. Reconnect the earth wire (PE) to the housing cover. Now secure the housing cover to the Sunny Boy SB 1100 by tightening the four screws evenly.
2. Connect the PV generator.
3. Switch the line circuit breaker to the "on" position.
4. Now check whether the LED display on the Sunny Boy SB 1100 indicates that the device is functioning correctly.



## 8 Technical data

### 8.1 PV generator connection data

Description	Short descr.	Setting
Max. input open circuit voltage	$U_{PV0}$	400 V (based on -10 °C cell temperature)
Input voltage, MPP range	$U_{PV}$	139 V ... 400 V
Max. input current	$I_{PV, max}$	10 A
Max. input power	$P_{DC}$	1210 W
Recommended total generator power		1350 Wp (for central Europe)
All-pole isolator on the DC input side		DC plug connector
Overvoltage protection		Thermally monitored varistors
Voltage ripple	$U_{ss}$	< 10% of the input voltage
Insulation protection		Ground fault monitoring (Riso > 1 MOhm)
Operating consumption		< 4 W (standby)
Reverse polarity protection		via short circuit diode

## 8.2 Grid connection data

Description	Short descr.	Settings
Nominal output power	$P_{ACnom}$	1000 W
Continuous output power (at 45 °C)		1000 W
Peak output power	$P_{ACmax}$	1100 W
Nominal output current	$I_{ACnom}$	4.4 A
Harmonic distortion of output current (at $K_{Ugrid} < 2\%$ , $P_{AC} > 0.5 P_{ACnom}$ )	$K_{IAC}$	< 4 %
Short-circuit strength		Grid-side via current regulation
Operating range, grid voltage	$U_{AC}$	198 ... 253 V AC
Operating range, grid frequency	$f_{AC}$	47,55 ... 50.2 Hz
All-pole isolation on grid side		Independent disconnection device ("SMA grid guard 2"), double implementation
Phase shift angle (based on the current's fundamental frequency)	cos phi	1
Overvoltage category		III
Test voltage (50 Hz)		1.7 kV (1 s routine testing / 5 s type testing)
Test surge voltage		4 kV (serial interface: 6 kV)
Own consumption in night mode		0.1 W

## 8.3 Device description

For a detailed description of the devices, see the operating instructions.

### General data

Protection category per DIN EN 60529	IP65
Dimensions (w x h x d)	434 mm x 295 mm x 180 mm (approx.)
Weight	22 kg (approx.)

### External interfaces

Data transmission over mains power line	optional
Data transmission over separate data cable	optional, RS232 / RS485 electrically separated
Wireless data transmission	optional

### Efficiency

Max. efficiency	hmax	93 %
European standard efficiency	heuro	91,6 %

The efficiency of the Sunny Boy 1100 depends mainly on the input voltage of the connected PV strings. The lower the input voltage, the higher the efficiency.

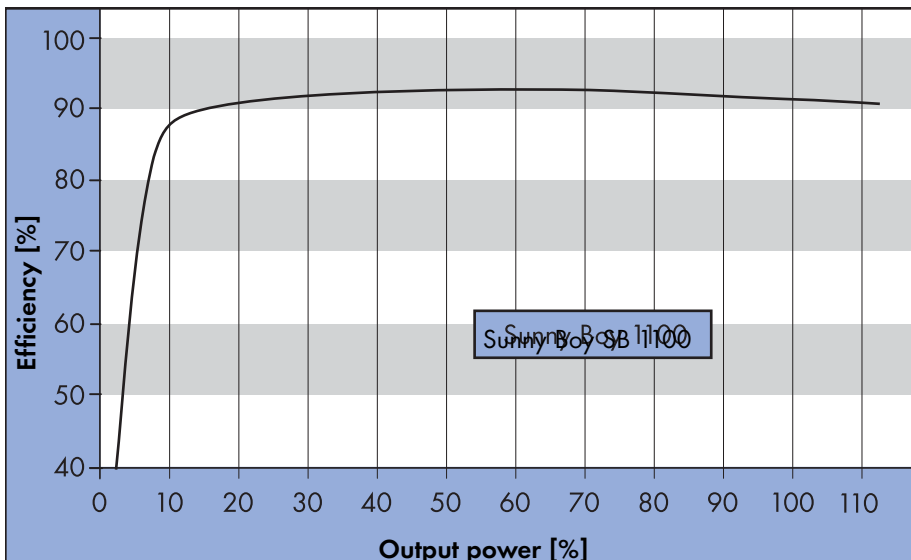

## 8.4 Operating parameters



### Warning!

Unauthorized changes to the operating parameters may result in:

- Injury or accidents as a result of changing the internal safety routines in the Sunny Boy
- Voiding the Sunny Boy's operating approval certificate
- Voiding the Sunny Boy's guarantee

Never change the parameters of your Sunny Boy without express authorization and instructions.

### 8.4.1 Explanation of the operating parameters

Name	Explanation
Antisland-Ampl	Amplification of the Antisland process (alternative Antislanding process, which is deactivated for Germany)
Antisland-Freq	Repetition rate of the Antisland process (alternative Antislanding process, which is deactivated for Germany)
Operating mode	Operating mode of the Sunny Boy: MPP: Maximum Power Point Konstantspg.: Constant voltage mode (Desired voltage is defined in "Usoll-Konst") Stop: Disconnection from mains network, no operation Turbine Mode: Operating mode for wind energy systems. Off Grid: Operating mode for Sunny Boys in a stand-alone grid.
Default	Used for setting the country specific-information. GER/VDE0126-1-1: country-specific parameter settings for Germany in accordance with DIN VDE 0126-1-1. AUS/AS4777: country-specific parameter settings for Australia. IT/DK5950: country-specific parameter settings for Italy. GB/G83: country-specific parameter settings for Great Britain. Trimmed: if country-specific parameters have been changed, "trimmed" is shown in the display. Off_Grid: setting for inverters which are operated in a stand-alone grid. More detailed information can be found in the Sunny Island manual.
dFac-Max	Maximum "Mains frequency change" before the mains monitoring system disconnects the device from the mains supply.

Name	Explanation
dZac-Max	Maximum "Mains impedance change" before the mains monitoring system disconnects the device from the mains supply.
E_Total	Total energy yield for the inverter. This change may be necessary when you replace your Sunny Boy and want to use the data from the old device.
Fac-delta-Fac-delta+	Maximum frequency, above (Fac-delta+) and below (Fac-delta-) the mains frequency, before the mains monitoring system disconnects the device from the mains supply.
h_Total	Total hours of operation for the inverter. This change may be necessary when you exchange your Sunny Boy and want to use the data from the old device.
I-Ni-Test	Setting the impulse for impedance monitoring. This parameter only functions when the Sunny Boy is deactivated (disconnected on the AC side) or in "Stopp" mode.
Inst.-Code	Parameters for self contained power system recognition can only be changed after entering the "SMA grid guard" password.
Plimit	Upper limit for AC output power
SMA-SN	Serial number of the Sunny Boy
Software-BFR	Firmware version of the operation control unit (BFR)
Software-SRR	Firmware version of the current control unit (SRR)
Storage function / Speicherfunktion	Default parameter: Returns all parameter values to the factory setting. Reset Betriebsdaten: Returns all user level parameter values to the factory setting. Reset Fehler: Resets a permanent fault.
Speicher/Storage	Permanent: Modified parameters are stored in the EEPROM and can be used even when the Sunny Boy has been restarted. Volatile: Prevents the parameters from being stored in the EEPROM, the parameters are only stored until the next restart.
T-Start	The period the Sunny Boy waits after the Upv-Start value has been reached.
T-Stop	The period the Sunny Boy waits before disconnecting from the mains supply when Pac drops below the set value.

Name	Explanation
Uac-Min Uac-Max	Lower (Uac-Min) and upper (Uac-Max) limits of the allowable AC voltage (Self contained power system recognition), before the mains supply monitoring system disconnects the device from the mains supply.
Upv-Start	The DC voltage required before the Sunny Boy begins feeding power into the mains supply.
Usoll-Konst	PV desired voltage for constant operational voltage. These parameters are only important when the "Betriebsart" parameter is set to U-konst.

## 8.4.2 Parameter settings for Germany

Grayed out parameters are only displayed in installer mode. The table below contains the parameters that are applicable in Germany.

Name	Unit	Value range	Factory setting
Antilsland-Ampl *	grd	0 ... 10	0
Antilsland-Freq *	mHz	0 ... 2000	500
Operating mode		MPP, Konstantspg., Stop, Turbine, Off Grid	MPP
Default *		GER/VDE0126-1-1, GB/G83, AUS/AS4777, USA/UL1741, IT/DK5950, Off_Grid, trimmed	GER/VDE0126-1-1
dFac-Max *	Hz/s	0,005 ... 4,0	0,25
dZac-Max *	mOhm	0 ... 2000	750
E_Total	kWh	0 ... 200000	
Fac-delta- *	Hz	0 ... 4,5	2,45
Fac-delta+ *	Hz	0 ... 4,5	0,19
h_Total	h	0 ... 200000	
I-NiTest *	mA	0 ... 8000	8000

Name	Unit	Value range	Factory setting
Storage function / Speicherfunktion		Default Parameter, Reset Operating Data, Reset Fault	None
Speicher/Storage		permanent, volatile	
T-Start *	s	5 ... 300	10
T-Stop	s	1 ... 3600	2
Uac-Min *	V	180 ... 300	198
Uac-Max *	V	180 ... 300	253
Upv-Start	V	150 ... 400	180
Usoll-Konst	V	150 ... 430	430

Parameters designated with \* are safety-related grid monitoring parameters. To change the SMA grid guard parameters, you must enter your personal SMA grid guard password (Inst.-Code). Please call the Sunny Boy Hotline to obtain your personal SMA grid guard password.



### 8.4.3 Country-specific parameter settings

The parameters listed below represent country-specific settings and are only displayed in installer mode. All other parameters are international and can be viewed in the table in section 8.4.2.

Name	Unit	Country settings			
		Germany	Great Britain	Australia	Italy
Default		GER/VDE 0126-1-1	GB/G83	AUS/AS4777	IT/DK5950
dFac-Max	Hz/s	0,25	0,2	0,250	0,200
dZac-Max	mOhm	825	350	20000	350
Fac-delta-	Hz	2,45	0,5	0,19	0,29
Fac-delta+	Hz	0,19	0,5	0,19	0,29
I-Ni-Test	mA	8000	0	4000	0
T-Start	s	10	180	45	10
Uac-Min	V	198	209	205	198
Uac-Max	V	253	261	265	262

### 8.4.4 Non-modifiable parameters

The following parameters are displayed in the parameter list but cannot be changed:

Name	Unit	Factory setting
Plimit	W	1100
SMA-SN		
Software-BFR		
Software-SRR		

## 8.5 Certificates

### 8.5.1 CE declaration of conformity

# CE Declaration of Conformity



for utility interactive inverters

**Product:** Sunny Boy  
**Type:** SB 700, SB 1100, SB 1100LV, SB 1700, SB 2100TL,  
 SB 2500, SB 2800i, SB 3000, SB 3300TL, SB 3300TL HC

We declare that the above specified devices are compliant with the regulations of the European Community, in terms of the design and the version fabricated by SMA. This especially applies for the EMC Regulation defined in 89/336/EWG and the LV- regulation defined in 73/23/EWG.

The devices are compliant with the following standards:

EMC:	
Emission:	DIN EN 61000-6-3: 2002-08 DIN EN 61000-6-4: 2002-08 DIN EN 55022: 2003-09, Class B
Utility Interference:	DIN EN 61000-3-3: 2002-05 DIN EN 61000-3-2: 2001-12 DIN EN 61000-6-1: 2002-08
Immunity:	DIN EN 61000-6-2: 2002-08 DIN EN 50178: 1998-04
Safety:	DIN EN 50178: 1998-04
Semiconductor-Converter:	DIN EN 60146-1-1: 1994-03

**The above mentioned devices are therefore marked with a CE sign.**

Note:  
 This declaration of conformity becomes invalid in case  
 - the product is modified, complemented or changed,  
 - and/or components, other than those belonging to the SMA accessories, are installed in the product,  
 - as well as in case of incorrect connection or improper usage  
 without explicit written confirmation by SMA.

Niestetal, 13.03.2006

**SMA Technologie AG**

*i. V. Frank Greizer*  
 i.V. Frank Greizer  
 (Head of Development Department Solar Technology)

**SMA Technologie AG**

Hannoversche Strasse 1-5  
 34266 Niestetal  
 Tel. +49 561 9522 - 0  
 Fax +49 561 9522 - 100  
 www.SMA.de  
 info@SMA.de



SB-K16/ACE12/BE1706

## 8.5.2 SMA grid guard certificate

The Sunny Boy SB 1100 is equipped with the "SMA grid guard" independent disconnection device and it is covered by the industrial trade association "SMA grid guard" import certificate.

<p>Fachausschuss Elektrotechnik                  der Berufsgenossenschaftlichen Zentrale                  für Sicherheit und Gesundheit – BGZ                  des Hauptverbandes der gewerblichen Berufsgenossenschaften</p>				<p>BG                  Federführung:                  Berufsgenossenschaft                  der Feinmechanik                  und Elektrotechnik</p>	
<p>Fachausschuss Elektrotechnik, Postfach 51 05 80, 50941 Köln</p>					
<p>SMA Technologie AG                  Hannoversche Straße 1-5                  34266 Niestetal</p>					
Ihre Zeichen/Nachricht von	Unser Zeichen (Bitte stets angeben)	Bearbeiter	☎ (02 21) 37 78-	Datum	
	UB.010.17	PI/Ow	6312	25.01.2006	
<b>Unbedenklichkeitsbescheinigung</b>					
<b>Erzeugnis:</b>	Selbsttätig wirkende Schaltstelle (ENS)				
<b>Typ:</b>	SMA grid guard Version 2				
<b>Bestimmungsgemäße Verwendung:</b>	Selbsttätig wirkende, dem VNB unzugängliche Schaltstelle als Sicherheitsschnittstelle zwischen einer Eigenerzeugungsanlage und dem Niederspannungsnetz. Gleichwertiger Ersatz für eine jederzeit dem VNB zugängliche Schaltstelle mit Trennfunktion.				
<b>Prüfgrundlage:</b>	DIN V VDE V 0126-1-1 (2006-02) "Selbsttätige Schaltstelle zwischen einer netzparallelen Erzeugungsanlage und dem öffentlichen Niederspannungsnetz"				
Das Sicherheitskonzept des o.g. Erzeugnisses, entspricht den zum Zeitpunkt der Ausstellung dieser Bescheinigung geltenden sicherheitstechnischen Anforderungen für die aufgeführte bestimmungsgemäße Verwendung.					
Die Unbedenklichkeitsbescheinigung wird spätestens					
<b>31.12.2010</b>					
ungültig.					
 - Mehlem - Leiter der Prüf- und Zertifizierungsstelle					
Hausadresse:	Quarta+Heinemann Ufer 130	50968 Köln	☎ (02 21) 37 78-63 01	Fax: (02 21) 37 78-63 22	

## 9 Replacing the varistors

The Sunny Boy SB 1100 is a complex high-technology device. As a result, the possibilities for fixing faults on site are limited to just a few items. Please don't try to carry out repairs other than those described here. Use the **SMA Technologie AG** 24-hour exchange service and repair service instead.

If the red LED on the status display glows continuously during operation, you should first of all make sure that there is no ground fault in the PV generator.

1. Disconnect the Sunny Boy SB 1100 from the low voltage grid (switch the line circuit breaker to its "off" position). Make sure the grid cannot be inadvertently reconnected and that no voltage is present at the AC output before opening the Sunny Boy.
2. Disconnect the DC plug connectors for all strings.

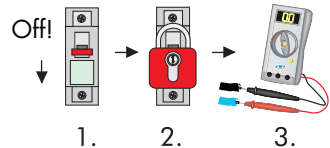

3. Taking one DC plug connector at a time, measure the voltages between one DC plug connector of a string and earth potential. Pay attention to the safety instructions!

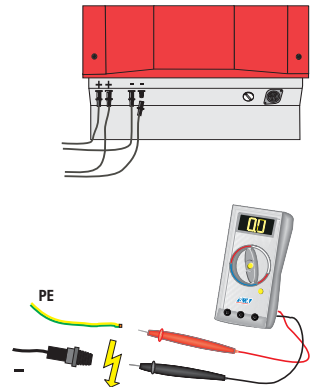

### Warning!

**Dangerous high voltages may be present. Danger of death!**



4. If the measured voltages are constant and if their total is roughly the same as the open circuit voltage of the string, then there is an ground fault in this string. Its approximate location can be deduced from the relationships between the voltages.
5. Repeat points 3 and 4 for each string.

If you found a ground fault, it is probably not necessary to replace the varistors. Instead, make sure the ground fault is fixed. Generally the PV generator's installation engineer should be hired for this job. In this case continue as described under point 10, but without reconnecting the faulty string. Instead of reconnecting the string, protect its DC plug against accidental touch contact (e.g. by fitting the protective caps or using sufficient high-voltage insulating tape).

If you did not find any ground fault in the PV generator, it is likely that one of the thermally monitored varistors has lost its protective function. These components are wearing parts. Their functioning diminishes with age or following repeated responses as a result of overvoltages. You can now check these varistors in the following way, paying attention to the safety instructions in section 3 „Safety instructions“ (Seite 9):

6. Remove the screws that secure the cover and remove the cover from the Sunny Boy SB 1100. Disconnect the PE connection from the cover. Make sure that no voltage is present.
7. Using a continuity tester, check all the varistors to see if there is a conducting connection between connectors 2 and 3. If there is no connection, then that varistor is not working. The positions of the varistors in the Sunny Boy SB 1100 can be seen in the diagram in section 4.1 „Unit description“ (Seite 11).

8. Replace the varistor concerned with a new one as shown in the drawing to the right. Ensure the varistor is installed the right way round! If you do not receive a special tool for operating the terminal clamps with your replacement varistors, please contact SMA. As an alternative, the terminal contacts can be operated using a suitable screwdriver. Since the failure of one varistor is generally due to factors that affect all varistors in a similar way (temperature, age, inductive overvoltages), it is highly recommended that you replace both varistors, not just the one that is obviously defective. The varistors are specially manufactured for use in the Sunny Boy SB 1100 and are not commercially available. They must be ordered directly from SMA Technologie AG (SMA order code: "SB-TV3").

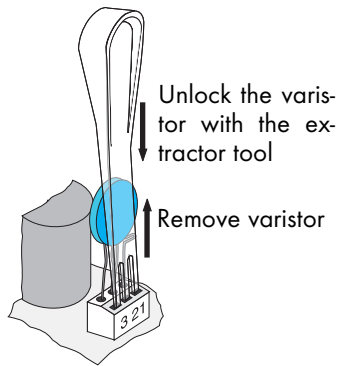

The wire with the little dent must be inserted into the terminal number 1 when you install the new varistor.



**Caution!**

**If no spare varistors are available on site, the Sunny Boy SB 1100 can once again feed into the grid. The input is no longer protected against overvoltages! Replacement varistors should be obtained as soon as possible. In systems with a high risk of overvoltages, the Sunny Boy SB 1100 should not be operated with defective varistors!**

9. Reconnect the PE connection to the cover and close the Sunny Boy SB 1100.

10. Connect up the faultless PV generator strings to the inverter.
11. Close the unnecessary DC input sockets with the caps included in the delivery.
12. Switch the line circuit breaker to the "on" position.
13. Now check whether the LED display on the Sunny Boy SB 1100 indicates that the device is functioning correctly.

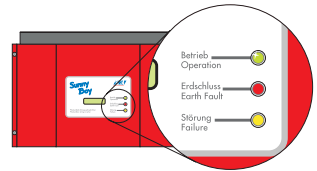
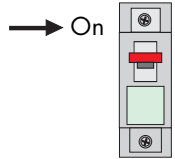
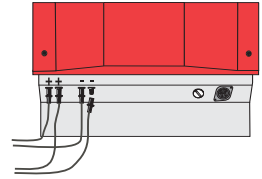

If no ground fault and no defective varistor were found, there is probably a fault in the Sunny Boy. In this case, contact the SMA hotline to discuss what to do next.



## 10 Rating for a line circuit breaker

Example for the thermal rating for a line circuit breaker in a photovoltaic electrical power unit operated in parallel with the low-voltage grid



We assume a PV system with 9 Sunny Boy SB 1100 inverters, with three inverters per phase.

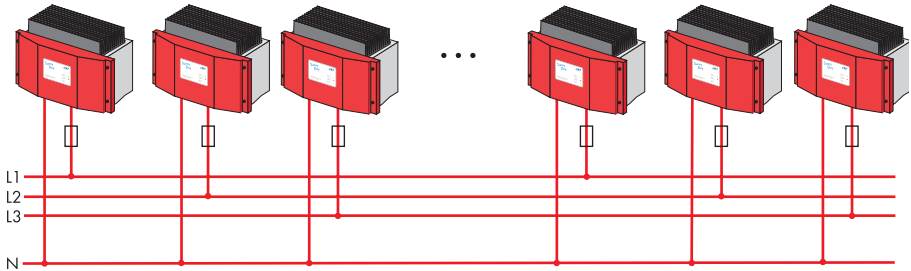

### Required technical information for the inverters used

- Maximum output current = 6 A
- Maximum permissible fuse protection for the inverter = 16 A

The choice of cable together with the way it is routed, ambient temperatures and other underlying conditions limit the maximum fuse protection for the cable.

- In our example we assume that the chosen cable (2.5 mm<sup>2</sup>) is ideally routed and can take a nominal current of 11 A.

### Selecting a line circuit breaker:

- The maximum possible nominal current for the cable used and the maximum possible fuse protection for the inverter now limit the maximum possible nominal current for the line circuit breaker.
- In our example, 10 A is possible.

However, the thermal suitability of the line circuit breaker still needs to be checked.

When selecting line circuit breakers, a number of load factors need to be taken into account. These can be found in the respective data sheets.



Example for the thermal selection of a 10 A line circuit breaker with B sensitivity with no gap between the circuit breakers:

For example, one manufacturer's circuit breaker may be designed for an ambient temperature of 50 °C.

### Load factors according to data sheet specifications:

- Reduction through permanent load >1h = 0.9<sup>1</sup>
- Reduction when 9 circuit breakers are arranged side-by-side without gaps = 0.77<sup>2</sup>
- Increase in nominal current as a result of ambient temperatures of 40 °C in the circuit breaker panel = 1.07<sup>3</sup>

### Result:

The nominal load current for the line circuit breaker is calculated as:

$$I_{bn} = 10 \text{ A} \times 0.9 \times 0.77 \times 1.07 = 7.4 \text{ A}$$

- 
1. Permanent loads of longer than 1 hour are possible in photovoltaics.
  2. When only one circuit breaker is used, the factor = 1
  3. Because the circuit breakers are rated for 50 °C

## Summary:

The selected line circuit breaker can be used in our example case since the maximum current-carrying capacity for fault-free operation is higher than the maximum output current of the inverter used. It will stop under rated operating conditions!

If the calculated current-carrying capacity of the circuit breaker had been lower than the maximum output current from the inverter, the following solution might have been used:

By spacing the circuit breakers at an interval of 8 mm, the reduction factor would be 0.98 instead of 0.77. As a result, the maximum current-carrying capacity would be 9.4 A.

In addition to the thermal rating of the circuit breakers, the boundary conditions as laid out in section „Rating for a line circuit breaker in a photovoltaic electrical power unit operated in parallel with the low-voltage grid“ (Seite 16) and the applicable DIN VDE standards also need to be taken into account, of course. The main ones that apply here are:

- DIN VDE 0100; part 410
- DIN VDE 0100; part 430
- DIN VDE 0298; part 4

In special applications the relevant standards must be followed.



# 11 The communications interface

**Installation or replacement of the communications interface is only to be carried out by a trained electrician.**



The communications interface is used to communicate with SMA communication devices (e. g. Sunny Boy Control, Sunny WebBox) or a PC with appropriate software (e. g. Sunny Data). Depending on the selected communications interface, up to 2500 inverters can be interconnected. Detailed information on this topic can be found in the communication device manual, or on the Internet at [www.SMA.de](http://www.SMA.de).

The detailed wiring diagram for the individual communications interfaces can be found in the communication device manual. This wiring diagram includes:

- specifications of the necessary cable type
- which of the inverter's connections are used
- whether jumpers need to be mounted, and if so, which jumpers
- whether the PE needs to be connected to the cable shield

The next pages will describe the following:

- the housing feed-throughs for the communications interface
- the permitted cable route in the Sunny Boy
- the location of the PE connector
- the location of the screw terminals for connection of communication wires
- the location of the jumper slots
- the location of the interface port

## 11.1 Connection of the interface



**When opening the Sunny Boy, follow all the safety instructions as described in section 3.**



*Electrostatic discharges are an acute danger to the Sunny Boy and to the communications interface. Ground yourself by touching PE before removing the communications interface from the packaging, and before touching any components within the Sunny Boy.*



*Read the communication device manual before beginning installation work. Further wiring details can be found there.*

1. Open the inverter as described in section 7.1.
2. Guide the PG screw fitting over the communication cable.
3. Thread the cable through the cable feed-throughs (A) on the Sunny Boy. Use one or two cable feed-throughs, depending on the type of cable used. Use the right enclosure feed-through for the Radio Piggy-Back.
4. Screw the PG screw fitting onto the Sunny Boy.
5. Sheathe the cable inside the Sunny Boy using the silicon tube provided. The silicon tube is imperative for safety reasons. Without this silicon tube, the interface is not to be operated.
6. Lay the cable in area (B) as shown in the figure to the right.
7. Ground the cable shield at the PE connector (C) if the terminal connection diagram of the communication device indicates this as necessary.
8. Connect the communication wires to the screw terminal strip (D) as described in the terminal connection diagram of the communication device. Note down the connector color coding for the respective pin numbers. Connecting the receiver incorrectly can cause the devices to be damaged.
  - Pin 2 color: \_\_\_\_\_
  - Pin 3 color: \_\_\_\_\_
  - Pin 5 color: \_\_\_\_\_
  - Pin 7 color: \_\_\_\_\_
9. Connect the jumpers (E) if the terminal connection diagram of the communication device indicates this as necessary. The table shown to the right provides an overview of the jumper functions.
10. Plug the communications interface into the board (F).

11. Close the Sunny Boy as described in section 7.2.

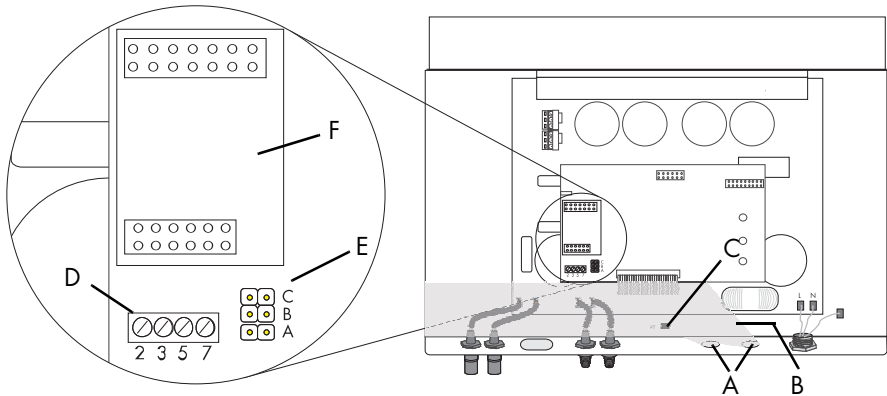

- A Housing feed-throughs in the base of the Sunny Boy
- B Cable route (gray surface)
- C PE connector
- D Screw terminals for connection of the communication wires
- E Jumper slot
- F Interface port

### 11.1.1 Jumper functions

	Jumper A	Jumper B	Jumper C
RS232	-	-	-
RS485	Termination	Bias 1	Bias 2
NLM	-	-	-
Sunny Beam	-	-	-

A detailed description of the jumper functions can be found in the communication device manual.





## 12 Contact

If you have any questions or technical problems concerning the Sunny Boy SB 1100, please contact our hotline. Have the following information available when you contact SMA:

- Inverter type
- Type and number of modules connected
- Communication method
- Serial number of the Sunny Boy
- Blink code or display of the Sunny Boy



Address:

**SMA** Technologie AG

Hannoversche Strasse 1 - 5

34266 Niestetal

Germany

Tel.: +49 (561) 95 22 - 499

Fax: +49 (561) 95 22 - 4699

hotline@SMA.de

[www.SMA.de](http://www.SMA.de)

The information contained in this document is the property of **SMA Technologie AG**. Publishing its content, either partially or in full, requires the written permission of **SMA Technologie AG**. Any internal company copying of the document for the purposes of evaluating the product or its correct implementation is allowed and does not require permission.

## Exclusion of liability

The general terms and conditions of delivery of **SMA Technologie AG** shall apply.

The content of these documents is continually checked and amended, where necessary. However, discrepancies cannot be excluded. No guarantee is made for the completeness of these documents. The latest version is available on the Internet at [www.SMA.de](http://www.SMA.de) or from the usual sales channels.

Guarantee or liability claims for damages of any kind are excluded if they are caused by one or more of the following:

- Improper or inappropriate use of the product
- Operating the product in an unintended environment
- Operating the product whilst ignoring relevant, statutory safety regulations in the deployment location
- Ignoring safety warnings and instructions contained in all documents relevant to the product
- Operating the product under incorrect safety or protection conditions
- Altering the product or supplied software without authority
- The product malfunctions due to operating attached or neighboring devices beyond statutory limit values
- In case of unforeseen calamity or force majeure

## Software licensing

The use of supplied software produced by **SMA Technologie AG** is subject to the following conditions:

This software may be copied for internal company purposes and may be installed on any number of computers. Supplied source codes may be changed or adapted for internal company purposes on your own responsibility. Drivers may also be transferred to other operating systems. Source codes may only be published with the written permission of **SMA Technologie AG**. Sub-licensing of software is not permissible.

Limitation of liability: **SMA Technologie AG** rejects any liability for direct or indirect damages arising from the use of software developed by **SMA Technologie AG**. This also applies to the provision or non-provision of support activities.

Supplied software not developed by **SMA Technologie AG** is subject to the respective licensing and liability agreements of the manufacturer.

## Trademarks

All trademarks are recognized even if these are not marked separately. Missing designations do not mean that a product or brand is not a registered trademark.

**SMA Technologie AG**

Hannoversche Straße 1-5

34266 Niestetal

Germany

Tel. +49 561 9522-0

Fax +49 561 9522-100

[www.SMA.de](http://www.SMA.de)

E-mail: [info@SMA.de](mailto:info@SMA.de)

© 2006 **SMA Technologie AG**. All rights reserved.



**Sales**  
**Solar Technology**

[www.SMA.de](http://www.SMA.de)

**SMA Technologie AG**  
**Hannoversche Strasse 1-5**  
**34266 Niestetal, Germany**  
**Tel.: +49 561 9522 4000**  
**Fax: +49 561 9522 4040**  
**E-Mail: [Info@SMA.de](mailto:Info@SMA.de)**  
**Freecall: +800 SUNNYBOY**  
**Freecall: +800 78669269**



Innovation in Systems Technology  
for the Success of Photovoltaics

